

STORMWATER MANAGEMENT PLAN



YORKSHIRE HIGHLANDS DEVELOPMENT (YORKVILLE 50TH ROAD)

Village of Yorkville, Racine County, Wisconsin
PEG Project Number: 1335.00-WI



Prepared for:

TNG10, LLC

3-02-21



PINNACLE ENGINEERING GROUP

20725 W. Watertown Road | Suite 100 | Brookfield, WI 53186

www.pinnacle-engr.com

TABLE OF CONTENTS

INTRODUCTION	2
DESIGN CRITERIA	2
PRE-DEVELOPMENT CONDITIONS	2
POST-DEVELOPMENT CONDITIONS	3
ANALYSIS METHODS	3
SUMMARY OF RESULTS	3
<i>Pre-Development Conditions</i>	3
<i>Post-Development Conditions</i>	4
<i>Runoff Water Quality</i>	5
CONCLUSION	6

APPENDICIES

APPENDIX 1 – MAPS

- Surface Water Data Viewer Map
- USDA SCS Soils Map
- Rainfall Data

APPENDIX 2 – PRE-DEVELOPMENT CONDITIONS INFORMATION

- Hydrology Exhibit – Pre-Development Conditions
- Hydrographs

APPENDIX 3 – POST-DEVELOPMENT CONDITIONS (RATE ATTENUATION)

- Hydrology Exhibit – Post-Development Conditions
- Hydrographs

APPENDIX 4 – POST-DEVELOPMENT CONDITIONS (WATER QUALITY)

- WinSLAMM Modeling Input Data & Output Computations

APPENDIX 5 – SOIL BORING DATA

Questions and comments can be directed to:

Aaron E. Koch, P.E.
Principal
Phone: 262.754.8888 | Fax: 262.754.8850
aekoch@pinnacle-engr.com



INTRODUCTION

The proposed project is generally located in the SW ¼ of Section 1, Township 3 North, Range 21 East in the Village of Yorkville, Racine County, Wisconsin. The existing subject property is approximately 87 acres in size. The proposed development consists of a single-family development with 15 lots along with three wet ponds. A location map that illustrates the tract of land is included in **Appendix 1**.

DESIGN CRITERIA

Village of Yorkville..... Chapter 10, Code of Ordinances

Wisconsin Department of Natural Resources..... NR 216 & NR 151

Water Quantity: The Village Ordinance and NR 151 require that the post-construction peak runoff discharge rates do not exceed the pre-development peak runoff discharge rates for the 1-year/24-hour and 2-year/24-hour storm events. The Village Ordinance also requires that the post-construction peak runoff discharge rate for the 100-year/24-hour storm event be reduced to the pre-development peak runoff discharge rate for the 10-year/24-hour storm event.

Water Quality: Both the Village Ordinance and NR 151 require removal of 80% of the annual total suspended solids (TSS) load for new development.

Infiltration: It is anticipated that the site is exempt from infiltration per Sec. 10-383 (d)(3)d2(c)i and NR 151.124(4)(c)1. Infiltration is not required for sites containing soils unsuitable for infiltration, in this case the soil is not suitable for infiltration.

Protective Areas: There are five less susceptible wetland areas on-site, three have been classified as artificial exempt. NR 151 requires a setback for less susceptible wetlands that is 10% of the average width no less than 10' nor greater than 30'. There is a 20' protective area around one wetland behind lots 7 and 8. The majority of the impervious area from these lots has sufficient distance to this protective area and should not affect the lots.

PRE-DEVELOPMENT CONDITIONS

Soils on the site are predominantly classified as Ashkum silty clay loam (C/D), Aztalan loam (C/D), Elliott silty clay loam (C/D), Markham silt loam (C), and Varna silt loam (C). Type C soils are being used for this analysis. Hydrologic soil group characteristics can be found in **Appendix 1**.

The existing site is comprised of mostly open farmland along with a gravel drive and is directly east of the East Branch of the Root River. Floodplain, secondary environmental corridor and three wetlands (delineated by Heartland Ecological) are present on the site. Wetlands that will be impacted are anticipated to be considered artificial wetlands. Secondary environmental corridor impacts are generally cropland that are currently impacted. The site generally slopes to the west towards the East Branch of the Root River.

POST-DEVELOPMENT CONDITIONS

It is proposed to construct a single-family residential subdivision with 15 lots. Stormwater will be managed by constructing three wet detention ponds. There is significant offsite water that flows to the creek from the east. The proposed drainage is created in such a way as to bypass the majority of the water via swales and culverts. Only a small amount of offsite water will come onto the site stormwater system on the north side. A Post-Development Hydrology Exhibit and Modeling can be found in **Appendix 3**.

ANALYSIS METHODS

HydroCAD® (Version 10.00) software has been used to analyze stormwater characteristics for this stormwater management plan. HydroCAD uses the accepted TR-55 methodology for determining peak discharge runoff rates. Rainfall depths for the 1, 2, 10, and 100-year storm events are 2.35, 2.67, 3.77, and 5.92 inches in accordance with the Village of Yorkville rainfall depths. The MSE3, 24-hour rainfall distribution was used. The rainfall data can be found in **Appendix 1**.

TSS reduction characteristics for the proposed water quality facilities were determined using WinSLAMM® (Version 10.4.0) Source Loading and Management Model.

SUMMARY OF RESULTS

Pre-Development Conditions

The entire site drains to the creek and is modeled as one area. The offsite that drains onto the site is modeled as a second. For the 1 and 2-year allowable discharges, the two are combined in the model. For the 10-year allowable, the 100-year offsite is combined manually since the offsite area does not need to be detained and can be passed through.

Allowable Peak Flows

Drainage Area	Area (ac)	CN	Tc (min)	Peak Flows 1-year (cfs)	Peak Flows 2-year (cfs)	Peak Flows 10-year (cfs)	Peak Flows 100-year (cfs)
EXISTING SITE	29.9	71	17.3	12.0	17.9	42.6	101.8
OFFSITE AREA	3.0	71	17.3	1.2	1.8	4.3	10.2
ALLOWABLE DISC.	32.9			13.2	19.7	N/A	52.8

Post-Development Conditions**Allowable Peak Flows**

Drainage Area	Area (ac)	CN	Tc (min)	Peak Flows 1-year (cfs)	Peak Flows 2-year (cfs)	Peak Flows 100-year (cfs)
SOUTH POND AREA	4.5	78	7.6	5.1	6.7	26.5
MIDDLE POND AREA	5.2	79	7.5	6.4	8.4	31.7
NORTH POND AREA	18.4	77	13.7	14.9	20.0	83.9
SOUTH AFTER DETENTION				0.3	0.3	4.8
MIDDLE AFTER DETENTION				0.3	0.4	5.3
NORTH AFTER DETENTION				0.9	1.0	23.6
UNDETAINED	1.8	78	6.0	2.2	2.9	11.2
PROPOSED SITE DISCHARGE	32.9			2.5	3.4	35.2

Wet Pond Data

Pond	Normal Water Elev.	Peak W.S. Elev. 1-year	Peak W.S. Elev. 2-year	Peak W.S. Elev. 100-year	Spillway Elev.	Top of Berm Elev.
SOUTH	716.0	716.6	716.8	718.4	719.0	719.5
MIDDLE	716.0	716.8	717.0	718.7	719.0	719.5
NORTH	716.0	717.1	717.4	719.5	719.5	720.0

A comparison of the peak flows from the site versus the allowable flows indicated that all of the flows have been detain to below allowable levels.

Runoff Water Quality

Post-development water quality will be obtained within the wet detention basins (see the Post-Development Hydrology Exhibit in **Appendix 3**).

Water Quality Summary

Area or Pond	Pounds of TSS Generated (No Controls)	Pounds of TSS Remaining (w/ Controls)	Percent Removal
SOUTH POND	597	77	87%
MIDDLE POND	827	111	87%
NORTH POND	2684	278	90%
UNDETAINED	307	307	0%
SITE TOTAL	4415	773.5	82.5%

This site will exceed the minimum 80% required TSS removal. Refer to **Appendix 4** for SLAMM modeling summary. A copy of the model data can be provided electronically upon request.

Infiltration

Infiltration is not required due to the lack of soils suitable for infiltration. Per NR 151 any soils containing clay are exempt from infiltration.

Protective Areas

There are five wetlands on the site classified as less susceptible. Three of the wetlands have been deemed Artificial exempt by the WDNR. Per NR151 a protective area will apply that is 10% of the average width, being no less than 10' or greater than 30'. The protective area is 20' around the wetland located behind lots 7 and 8. This protective area will not affect the lots as there is sufficient separation between potential impervious surfaces and the protective area.

CONCLUSION

The stormwater management features for the development have been designed to comply with the Village of Yorkville ordinance and WDNR NR216/151 requirements. Post-Development peak flows are less than pre-development peak flows for the 1-year/24-hour and 2-year/24-hour storm events. The post-development peak flow for the 100-year/24-hour storm event is less than the pre-development peak flow for the 10-year/24-hour storm event. Storm water runoff from the site will be treated to remove in excess of the required total suspended solids annually through the wet detention basins. Offsite areas have been accommodated in the design. The site is anticipated to be exempt from the infiltration requirement. A Stormwater Maintenance Agreement can be found in **Appendix 6**.

APPENDIX 1 MAPS

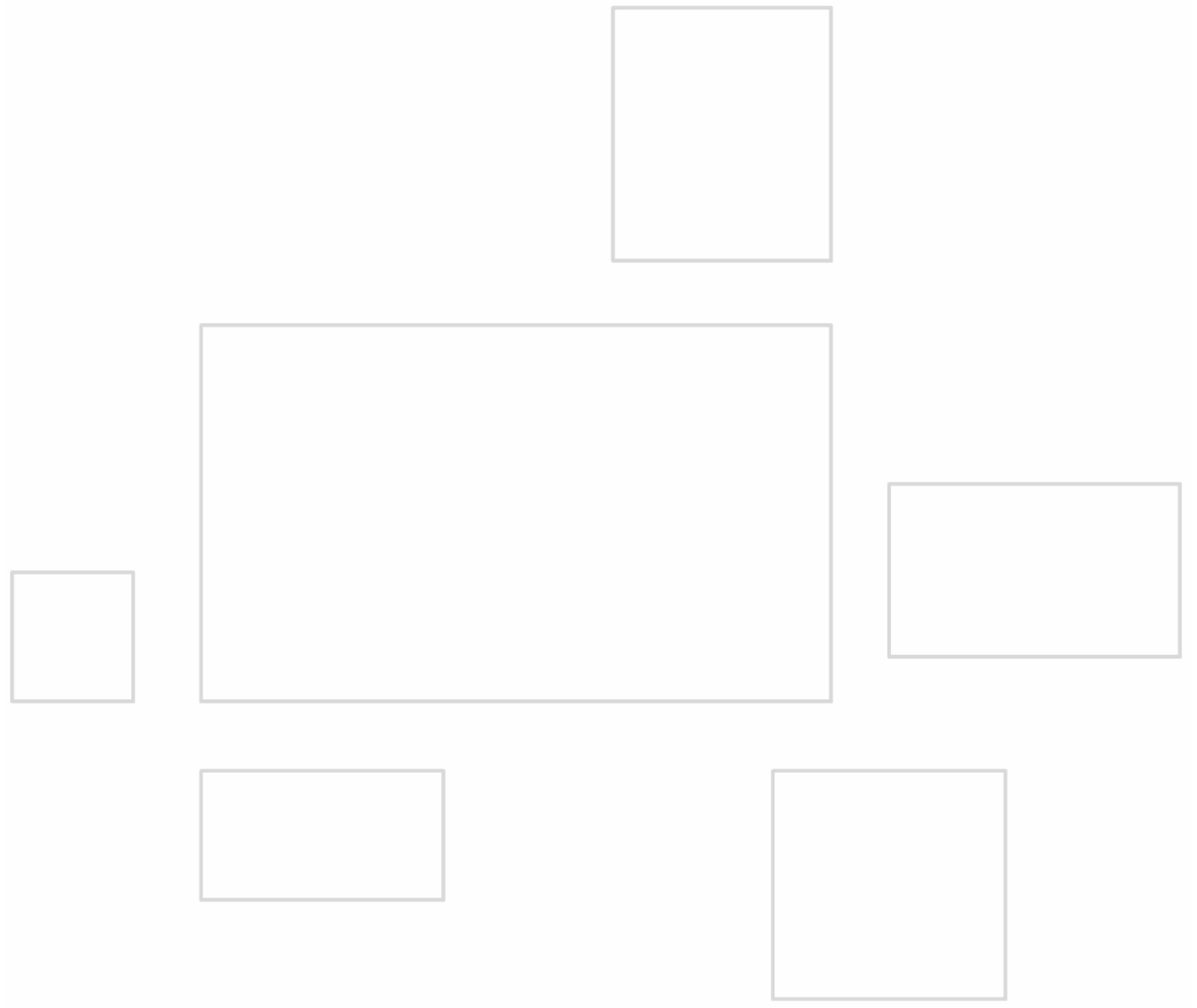



Surface Water Data Viewer Map



Legend

- Municipality
- State Boundaries
- County Boundaries
- Major Roads
 - Interstate Highway
 - State Highway
 - US Highway
- County and Local Roads
 - County HWY
 - Local Road
- Railroads
- Tribal Lands
- Rivers and Streams
- Intermittent Streams
- Lakes and Open water
- Index to EN_Image_Basemap_Leaf_Off

Notes

DISCLAIMER: The information shown on these maps has been obtained from various sources, and are of varying age, reliability and resolution. These maps are not intended to be used for navigation, nor are these maps an authoritative source of information about legal land ownership or public access. No warranty, expressed or implied, is made regarding accuracy, applicability for a particular use, completeness, or legality of the information depicted on this map. For more information, see the DNR Legal Notices web page: <http://dnr.wi.gov/legal/>

0.3 Miles



NAD_1983_HARN_Wisconsin_TM

1: 7,920

Hydrologic Soil Group—Kenosha and Racine Counties, Wisconsin

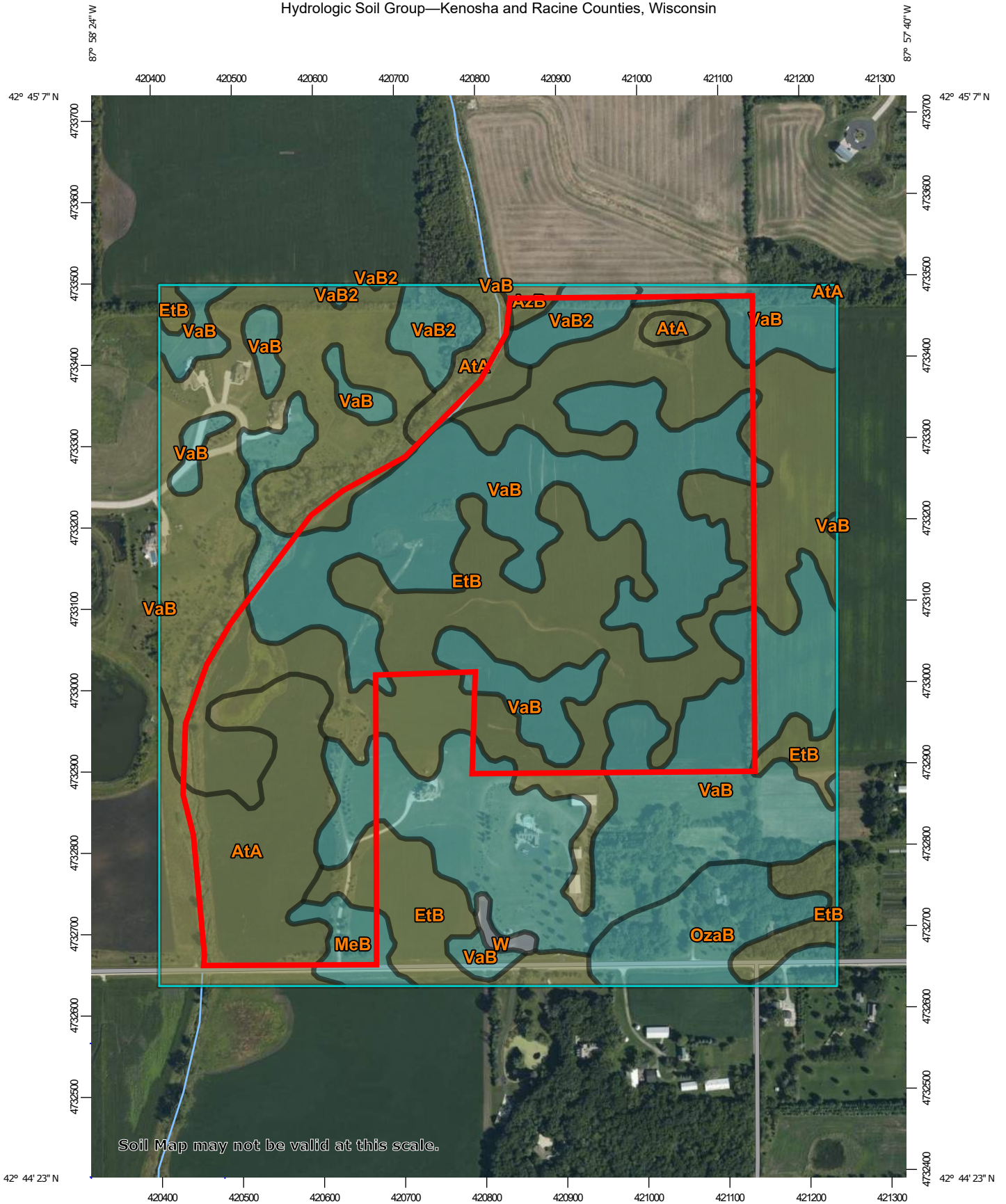

Soil Map may not be valid at this scale.

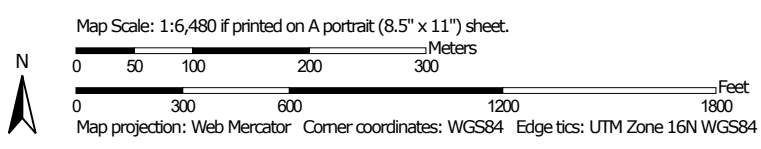

MAP LEGEND

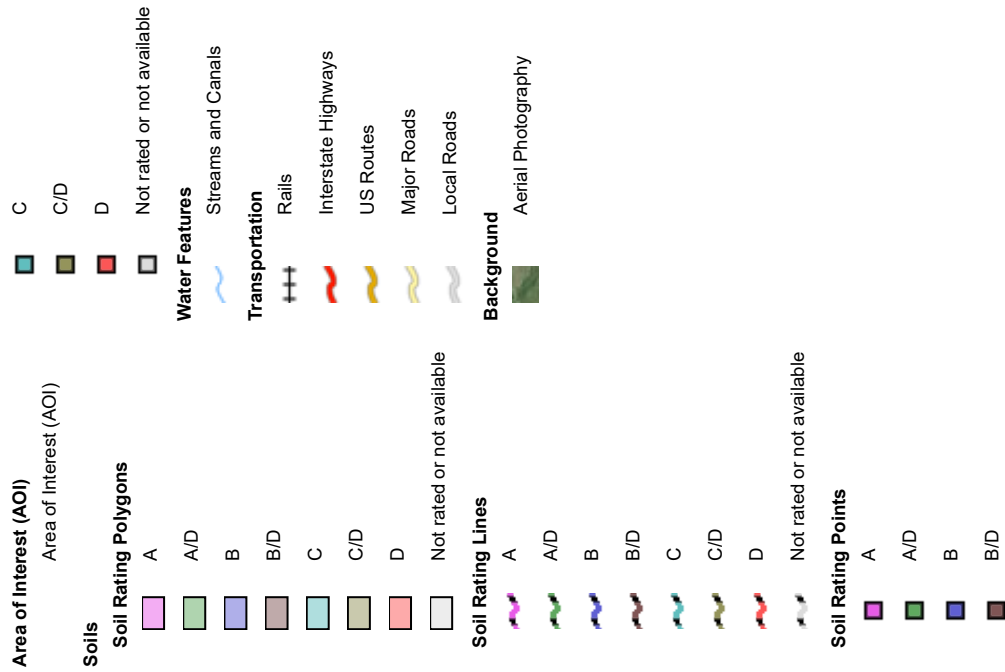

MAP INFORMATION

The soil surveys that comprise your AOI were mapped at 1:15,800.

Warning: Soil Map may not be valid at this scale.

Enlargement of maps beyond the scale of mapping can cause misunderstanding of the detail of mapping and accuracy of soil line placement. The maps do not show the small areas of contrasting soils that could have been shown at a more detailed scale.

Please rely on the bar scale on each map sheet for map measurements.

Source of Map: Natural Resources Conservation Service
 Web Soil Survey URL:
 Coordinate System: Web Mercator (EPSG:3857)

Maps from the Web Soil Survey are based on the Web Mercator projection, which preserves direction and shape but distorts distance and area. A projection that preserves area, such as the Albers equal-area conic projection, should be used if more accurate calculations of distance or area are required.

This product is generated from the USDA-NRCS certified data as of the version date(s) listed below.

Soil Survey Area: Kenosha and Racine Counties, Wisconsin
 Survey Area Data: Version 17, Jun 8, 2020

Soil map units are labeled (as space allows) for map scales 1:50,000 or larger.

Date(s) aerial images were photographed: Aug 24, 2019—Aug 28, 2019

The orthophoto or other base map on which the soil lines were compiled and digitized probably differs from the background imagery displayed on these maps. As a result, some minor shifting of map unit boundaries may be evident.

Hydrologic Soil Group

Map unit symbol	Map unit name	Rating	Acres in AOI	Percent of AOI
AtA	Ashkum silty clay loam, 0 to 2 percent slopes	C/D	19.0	10.6%
AzB	Aztalan loam, 2 to 6 percent slopes	C/D	0.6	0.4%
EtB	Elliott silty clay loam, 2 to 6 percent slopes	C/D	76.8	42.9%
MeB	Markham silt loam, 2 to 6 percent slopes	C	2.3	1.3%
OzaB	Ozaukee silt loam, 2 to 6 percent slopes	C	7.4	4.1%
VaB	Varna silt loam, 2 to 6 percent slopes	C	67.6	37.8%
VaB2	Varna silt loam, 2 to 6 percent slopes, eroded	C	4.6	2.6%
W	Water		0.5	0.3%
Totals for Area of Interest			178.8	100.0%

APPENDIX 2

PRE-DEVELOPMENT CONDITIONS

INFORMATION

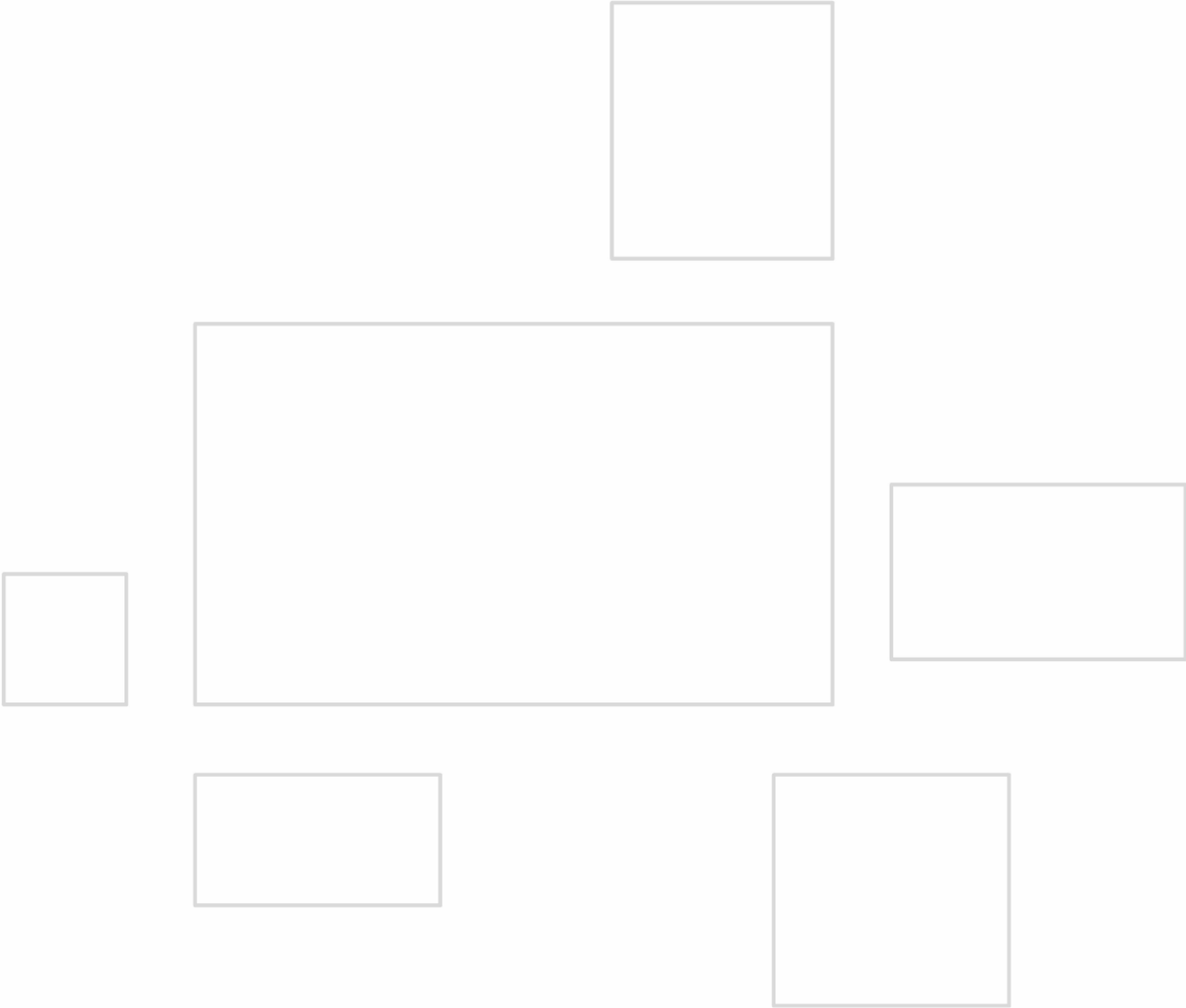

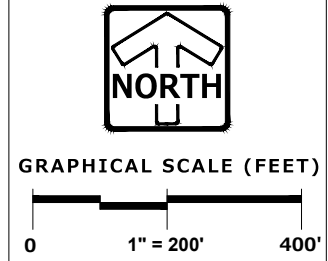
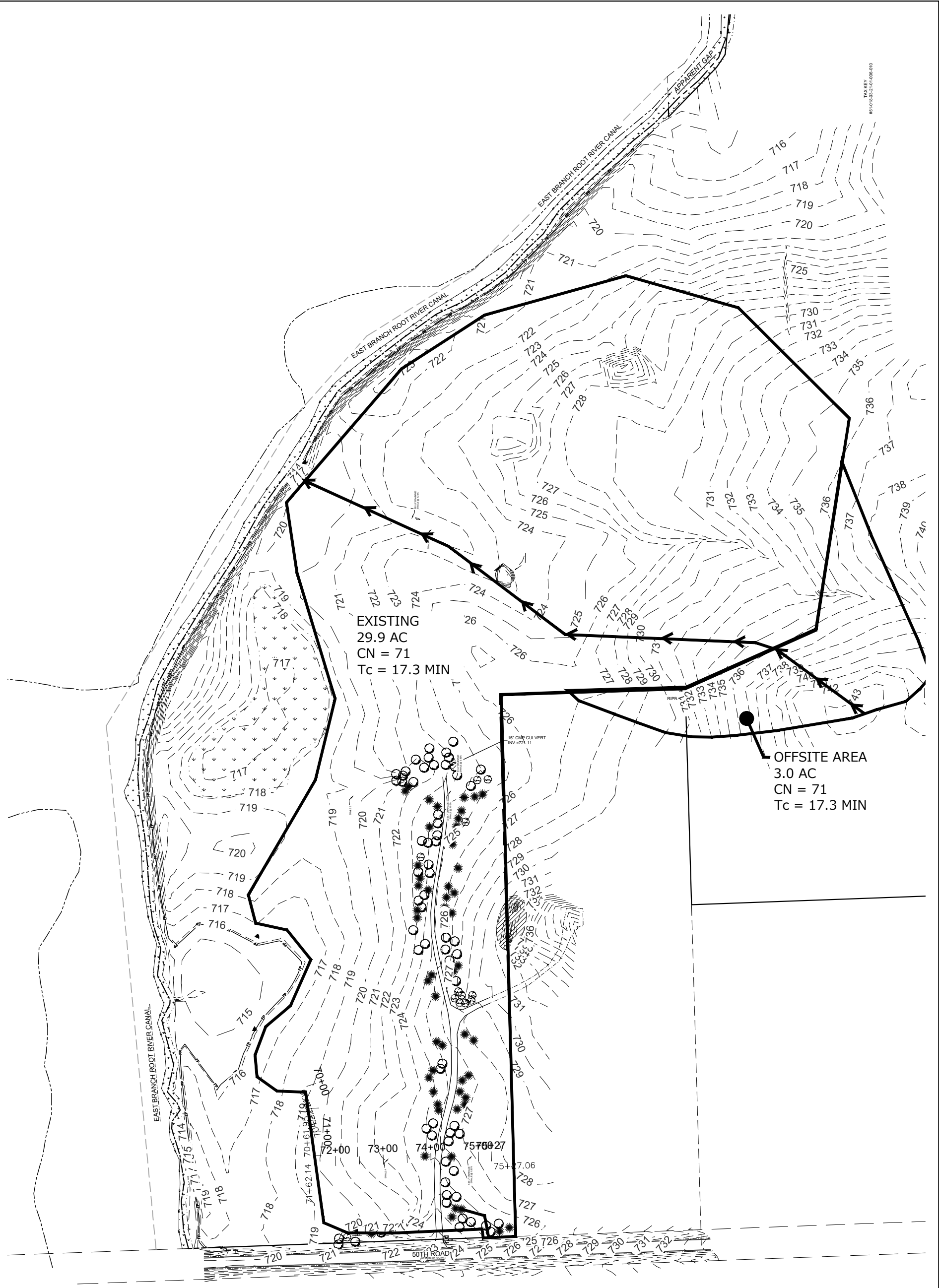

HYDROLOGY EXHIBIT - EXISTING

2-12-21

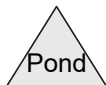
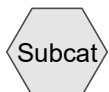
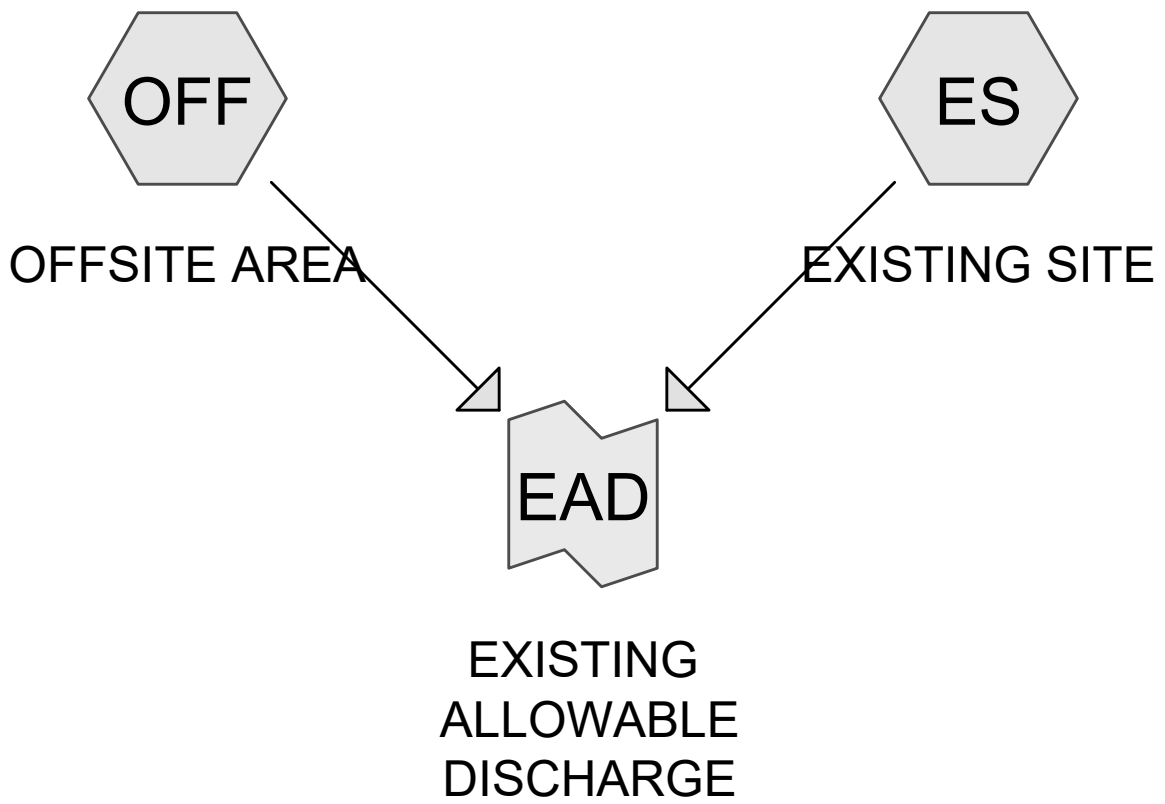

Routing Diagram for YORKVILLE

Prepared by {enter your company name here}, Printed 2/24/2021
HydroCAD® 10.00-22 s/n 07894 © 2018 HydroCAD Software Solutions LLC

YORKVILLE

MSE 24-hr 3 1-YEAR Rainfall=2.35"

Prepared by {enter your company name here}

Printed 2/24/2021

HydroCAD® 10.00-22 s/n 07894 © 2018 HydroCAD Software Solutions LLC

Page 2

Time span=5.00-20.00 hrs, dt=0.05 hrs, 301 points
Runoff by SCS TR-20 method, UH=SCS, Weighted-CN
Reach routing by Stor-Ind+Trans method - Pond routing by Stor-Ind method

SubcatchmentES: EXISTING SITE Runoff Area=29.900 ac 0.00% Impervious Runoff Depth>0.39"
Flow Length=1,320' Slope=0.0200 '/' Tc=17.3 min CN=71 Runoff=12.00 cfs 0.964 af

SubcatchmentOFF: OFFSITE AREA Runoff Area=3.000 ac 0.00% Impervious Runoff Depth>0.39"
Flow Length=1,320' Slope=0.0200 '/' Tc=17.3 min CN=71 Runoff=1.20 cfs 0.097 af

Link EAD: EXISTING ALLOWABLE DISCHARGE Inflow=13.20 cfs 1.061 af
Primary=13.20 cfs 1.061 af

Total Runoff Area = 32.900 ac Runoff Volume = 1.061 af Average Runoff Depth = 0.39"
100.00% Pervious = 32.900 ac 0.00% Impervious = 0.000 ac

YORKVILLE

MSE 24-hr 3 1-YEAR Rainfall=2.35"

Prepared by {enter your company name here}

Printed 2/24/2021

HydroCAD® 10.00-22 s/n 07894 © 2018 HydroCAD Software Solutions LLC

Page 3

Summary for Subcatchment ES: EXISTING SITE

Runoff = 12.00 cfs @ 12.31 hrs, Volume= 0.964 af, Depth> 0.39"

Runoff by SCS TR-20 method, UH=SCS, Weighted-CN, Time Span= 5.00-20.00 hrs, dt= 0.05 hrs
MSE 24-hr 3 1-YEAR Rainfall=2.35"

Area (ac)	CN	Description
* 29.600	71	AG LANDS
* 0.300	89	GRAVEL DRIVEWAY
29.900	71	Weighted Average
29.900		100.00% Pervious Area

Tc (min)	Length (feet)	Slope (ft/ft)	Velocity (ft/sec)	Capacity (cfs)	Description
17.3	1,320	0.0200	1.27		Shallow Concentrated Flow, SHALLOW CONCENTRATED Cultivated Straight Rows Kv= 9.0 fps

Subcatchment ES: EXISTING SITE

Hydrograph

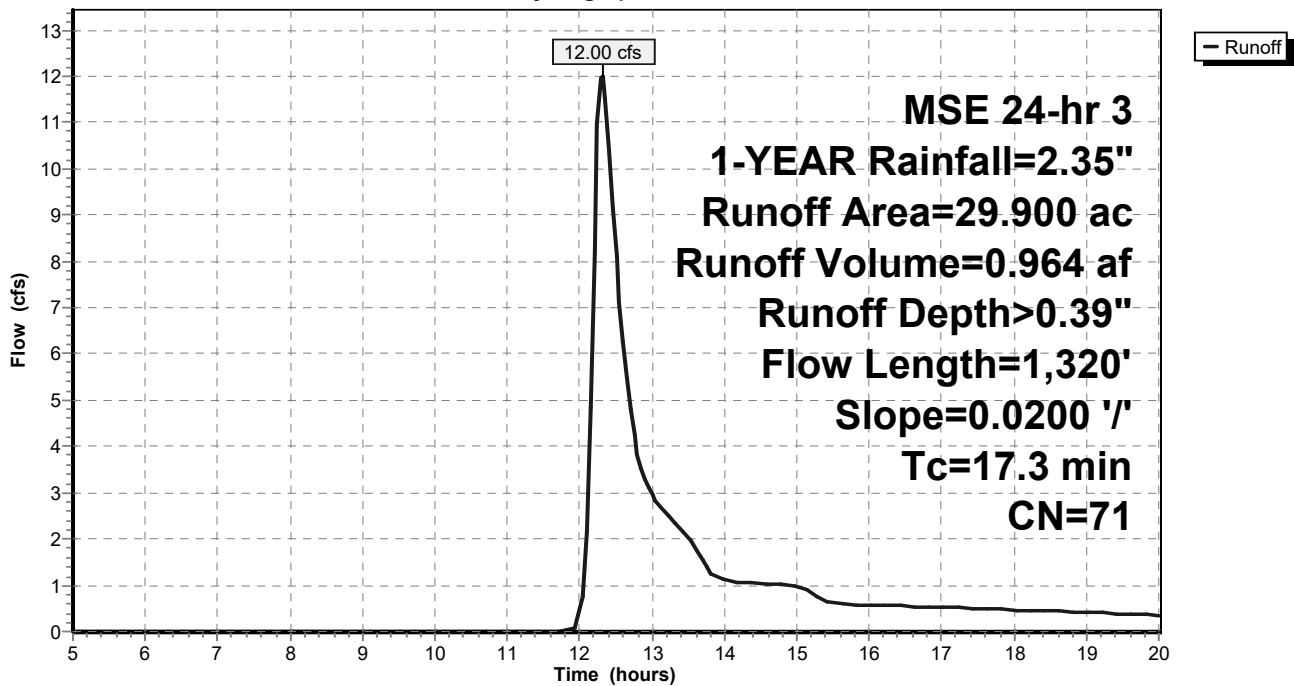

Summary for Subcatchment OFF: OFFSITE AREA

Runoff = 1.20 cfs @ 12.31 hrs, Volume= 0.097 af, Depth> 0.39"

Runoff by SCS TR-20 method, UH=SCS, Weighted-CN, Time Span= 5.00-20.00 hrs, dt= 0.05 hrs
MSE 24-hr 3 1-YEAR Rainfall=2.35"

Area (ac)	CN	Description
* 3.000	71	AG LANDS
3.000		100.00% Pervious Area

Tc (min)	Length (feet)	Slope (ft/ft)	Velocity (ft/sec)	Capacity (cfs)	Description
17.3	1,320	0.0200	1.27		Shallow Concentrated Flow, SHALLOW CONCENTRATED Cultivated Straight Rows Kv= 9.0 fps

Subcatchment OFF: OFFSITE AREA

Hydrograph

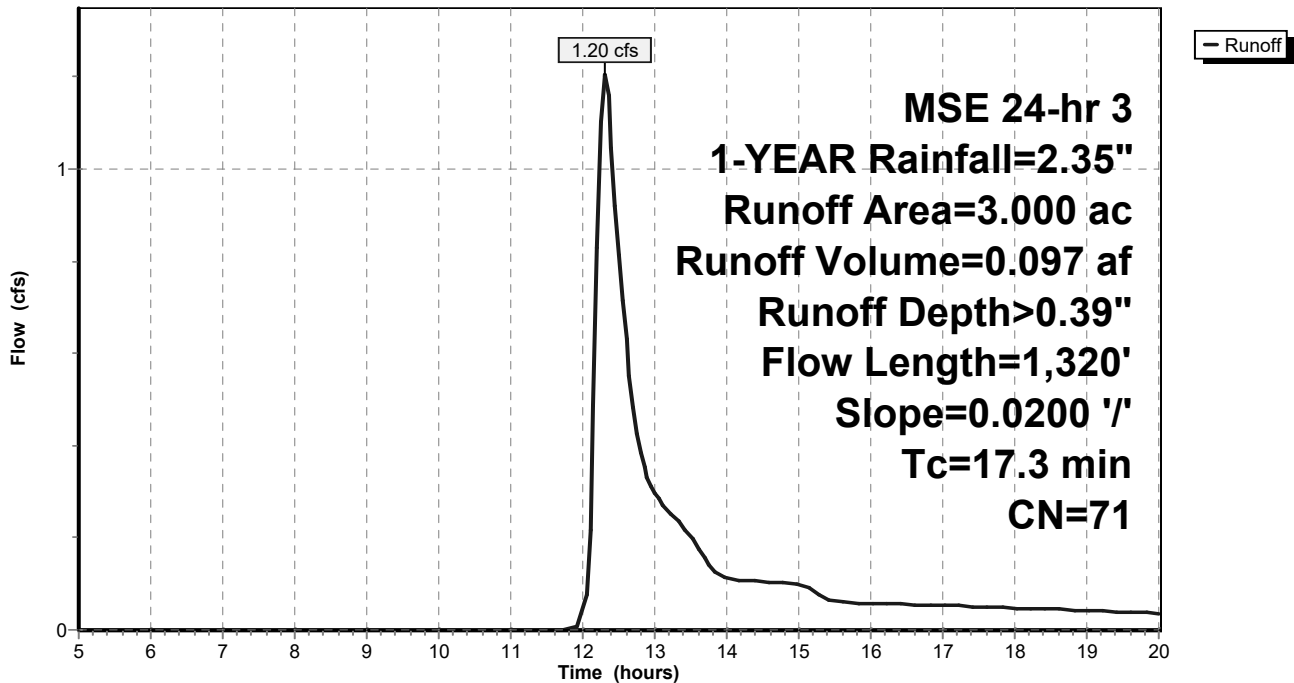

Summary for Link EAD: EXISTING ALLOWABLE DISCHARGE

Inflow Area = 32.900 ac, 0.00% Impervious, Inflow Depth > 0.39" for 1-YEAR event
Inflow = 13.20 cfs @ 12.31 hrs, Volume= 1.061 af
Primary = 13.20 cfs @ 12.31 hrs, Volume= 1.061 af, Atten= 0%, Lag= 0.0 min

Primary outflow = Inflow, Time Span= 5.00-20.00 hrs, dt= 0.05 hrs

Link EAD: EXISTING ALLOWABLE DISCHARGE

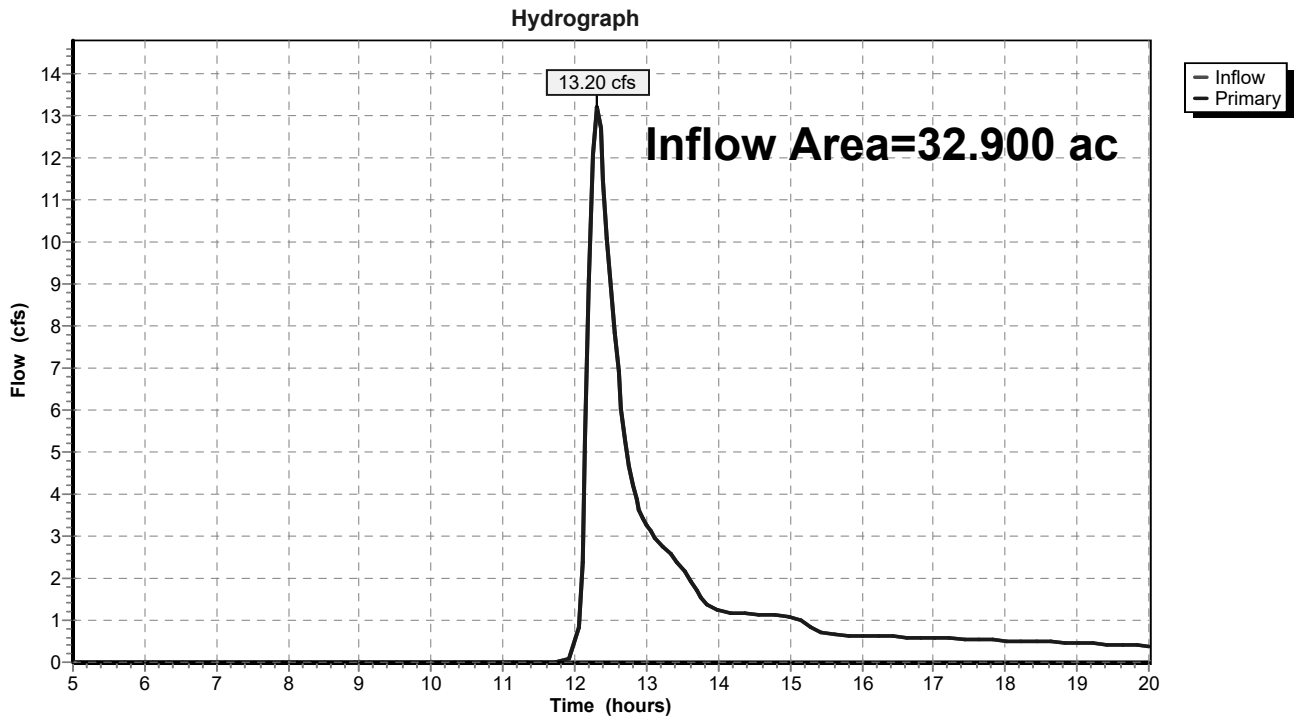

YORKVILLE

MSE 24-hr 3 2-YEAR Rainfall=2.67"

Prepared by {enter your company name here}

Printed 2/24/2021

HydroCAD® 10.00-22 s/n 07894 © 2018 HydroCAD Software Solutions LLC

Page 6

Time span=5.00-20.00 hrs, dt=0.05 hrs, 301 points
Runoff by SCS TR-20 method, UH=SCS, Weighted-CN
Reach routing by Stor-Ind+Trans method - Pond routing by Stor-Ind method

SubcatchmentES: EXISTING SITE Runoff Area=29.900 ac 0.00% Impervious Runoff Depth>0.54"
Flow Length=1,320' Slope=0.0200 '/' Tc=17.3 min CN=71 Runoff=17.93 cfs 1.342 af

SubcatchmentOFF: OFFSITE AREA Runoff Area=3.000 ac 0.00% Impervious Runoff Depth>0.54"
Flow Length=1,320' Slope=0.0200 '/' Tc=17.3 min CN=71 Runoff=1.80 cfs 0.135 af

Link EAD: EXISTING ALLOWABLE DISCHARGE Inflow=19.73 cfs 1.476 af
Primary=19.73 cfs 1.476 af

Total Runoff Area = 32.900 ac Runoff Volume = 1.476 af Average Runoff Depth = 0.54"
100.00% Pervious = 32.900 ac 0.00% Impervious = 0.000 ac

YORKVILLE

MSE 24-hr 3 2-YEAR Rainfall=2.67"

Prepared by {enter your company name here}

Printed 2/24/2021

HydroCAD® 10.00-22 s/n 07894 © 2018 HydroCAD Software Solutions LLC

Page 7

Summary for Subcatchment ES: EXISTING SITE

Runoff = 17.93 cfs @ 12.30 hrs, Volume= 1.342 af, Depth> 0.54"

Runoff by SCS TR-20 method, UH=SCS, Weighted-CN, Time Span= 5.00-20.00 hrs, dt= 0.05 hrs
MSE 24-hr 3 2-YEAR Rainfall=2.67"

Area (ac)	CN	Description
* 29.600	71	AG LANDS
* 0.300	89	GRAVEL DRIVEWAY
29.900	71	Weighted Average
29.900		100.00% Pervious Area

Tc (min)	Length (feet)	Slope (ft/ft)	Velocity (ft/sec)	Capacity (cfs)	Description
17.3	1,320	0.0200	1.27		Shallow Concentrated Flow, SHALLOW CONCENTRATED Cultivated Straight Rows Kv= 9.0 fps

Subcatchment ES: EXISTING SITE

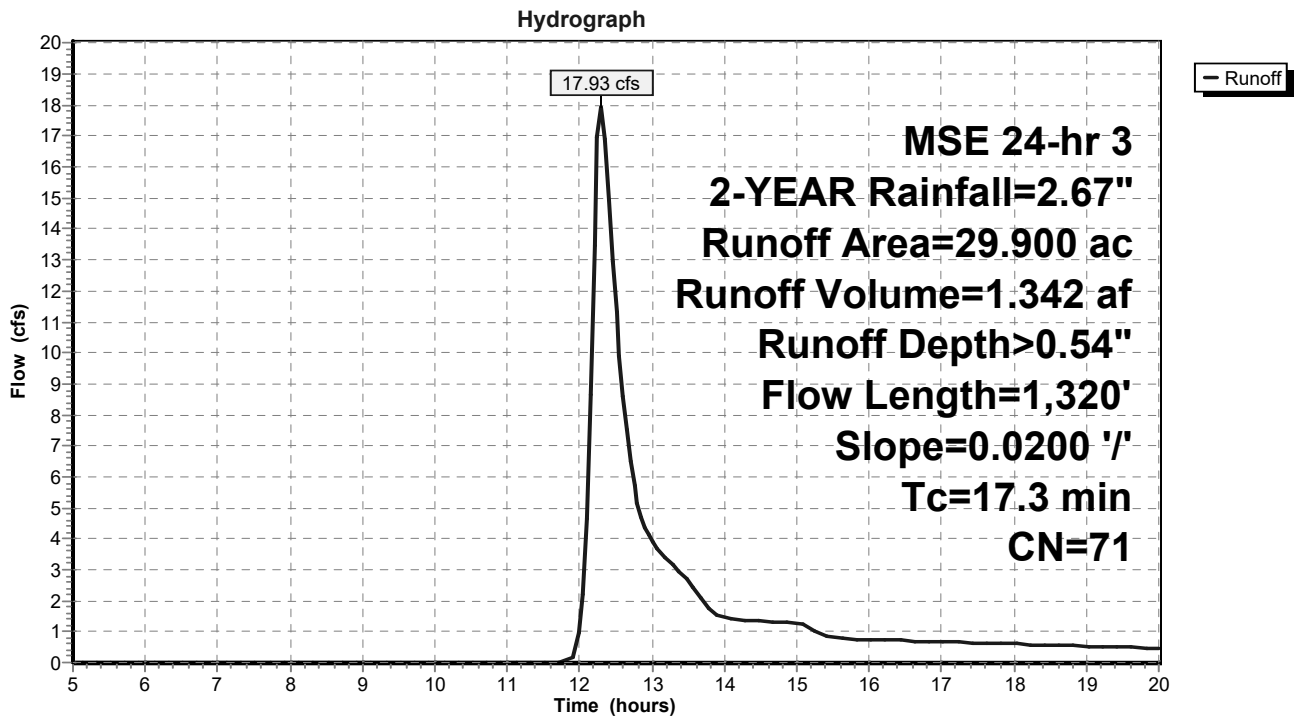

Summary for Subcatchment OFF: OFFSITE AREA

Runoff = 1.80 cfs @ 12.30 hrs, Volume= 0.135 af, Depth> 0.54"

Runoff by SCS TR-20 method, UH=SCS, Weighted-CN, Time Span= 5.00-20.00 hrs, dt= 0.05 hrs
 MSE 24-hr 3 2-YEAR Rainfall=2.67"

Area (ac)	CN	Description
* 3.000	71	AG LANDS
3.000		100.00% Pervious Area

Tc (min)	Length (feet)	Slope (ft/ft)	Velocity (ft/sec)	Capacity (cfs)	Description
17.3	1,320	0.0200	1.27		Shallow Concentrated Flow, SHALLOW CONCENTRATED Cultivated Straight Rows Kv= 9.0 fps

Subcatchment OFF: OFFSITE AREA

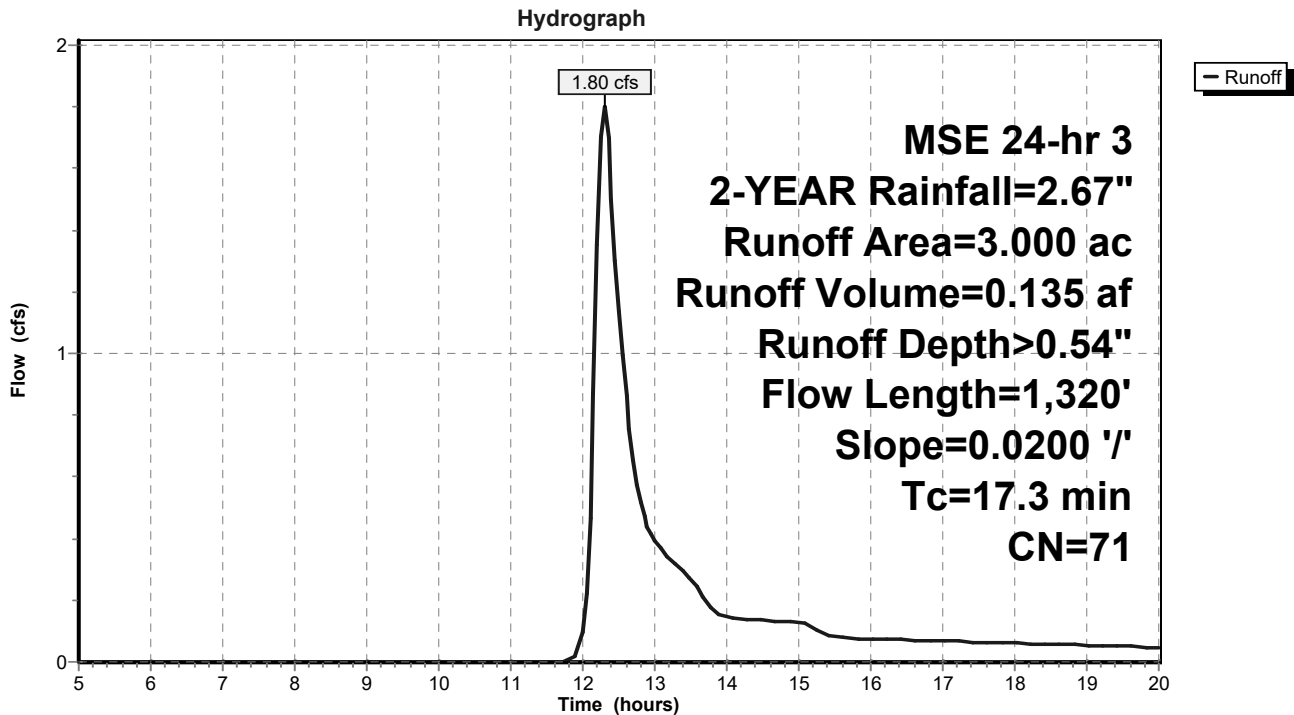

Summary for Link EAD: EXISTING ALLOWABLE DISCHARGE

Inflow Area = 32.900 ac, 0.00% Impervious, Inflow Depth > 0.54" for 2-YEAR event
Inflow = 19.73 cfs @ 12.30 hrs, Volume= 1.476 af
Primary = 19.73 cfs @ 12.30 hrs, Volume= 1.476 af, Atten= 0%, Lag= 0.0 min

Primary outflow = Inflow, Time Span= 5.00-20.00 hrs, dt= 0.05 hrs

Link EAD: EXISTING ALLOWABLE DISCHARGE

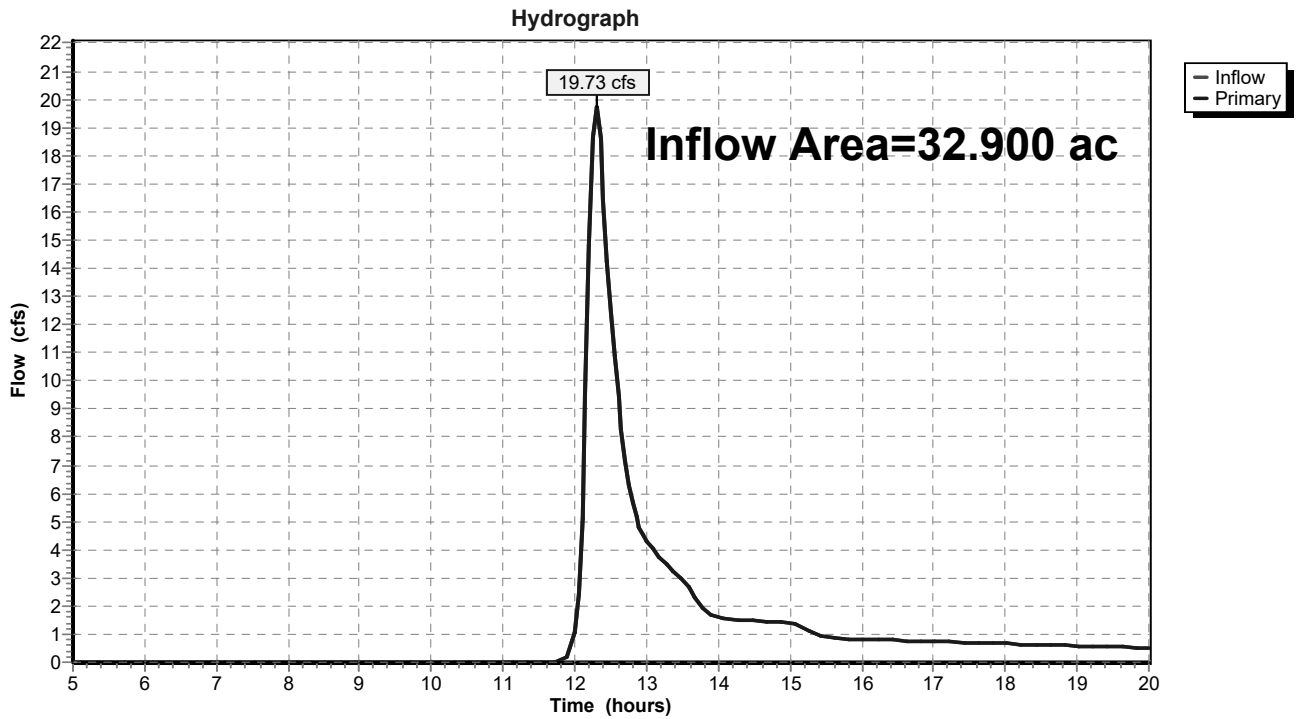

YORKVILLE

MSE 24-hr 3 10-YEAR Rainfall=3.77"

Prepared by {enter your company name here}

Printed 2/24/2021

HydroCAD® 10.00-22 s/n 07894 © 2018 HydroCAD Software Solutions LLC

Page 10

Time span=5.00-20.00 hrs, dt=0.05 hrs, 301 points
Runoff by SCS TR-20 method, UH=SCS, Weighted-CN
Reach routing by Stor-Ind+Trans method - Pond routing by Stor-Ind method

SubcatchmentES: EXISTING SITE Runoff Area=29.900 ac 0.00% Impervious Runoff Depth>1.17"
Flow Length=1,320' Slope=0.0200 '/' Tc=17.3 min CN=71 Runoff=42.59 cfs 2.910 af

SubcatchmentOFF: OFFSITE AREA Runoff Area=3.000 ac 0.00% Impervious Runoff Depth>1.17"
Flow Length=1,320' Slope=0.0200 '/' Tc=17.3 min CN=71 Runoff=4.27 cfs 0.292 af

Link EAD: EXISTING ALLOWABLE DISCHARGE Inflow=46.87 cfs 3.202 af
Primary=46.87 cfs 3.202 af

Total Runoff Area = 32.900 ac Runoff Volume = 3.202 af Average Runoff Depth = 1.17"
100.00% Pervious = 32.900 ac 0.00% Impervious = 0.000 ac

YORKVILLE

Prepared by {enter your company name here}

HydroCAD® 10.00-22 s/n 07894 © 2018 HydroCAD Software Solutions LLC

MSE 24-hr 3 10-YEAR Rainfall=3.77"

Printed 2/24/2021

Page 11

Summary for Subcatchment ES: EXISTING SITE

Runoff = 42.59 cfs @ 12.28 hrs, Volume= 2.910 af, Depth> 1.17"

Runoff by SCS TR-20 method, UH=SCS, Weighted-CN, Time Span= 5.00-20.00 hrs, dt= 0.05 hrs
MSE 24-hr 3 10-YEAR Rainfall=3.77"

Area (ac)	CN	Description
* 29.600	71	AG LANDS
* 0.300	89	GRAVEL DRIVEWAY
29.900	71	Weighted Average
29.900		100.00% Pervious Area

Tc (min)	Length (feet)	Slope (ft/ft)	Velocity (ft/sec)	Capacity (cfs)	Description
17.3	1,320	0.0200	1.27		Shallow Concentrated Flow, SHALLOW CONCENTRATED Cultivated Straight Rows Kv= 9.0 fps

Subcatchment ES: EXISTING SITE

Hydrograph

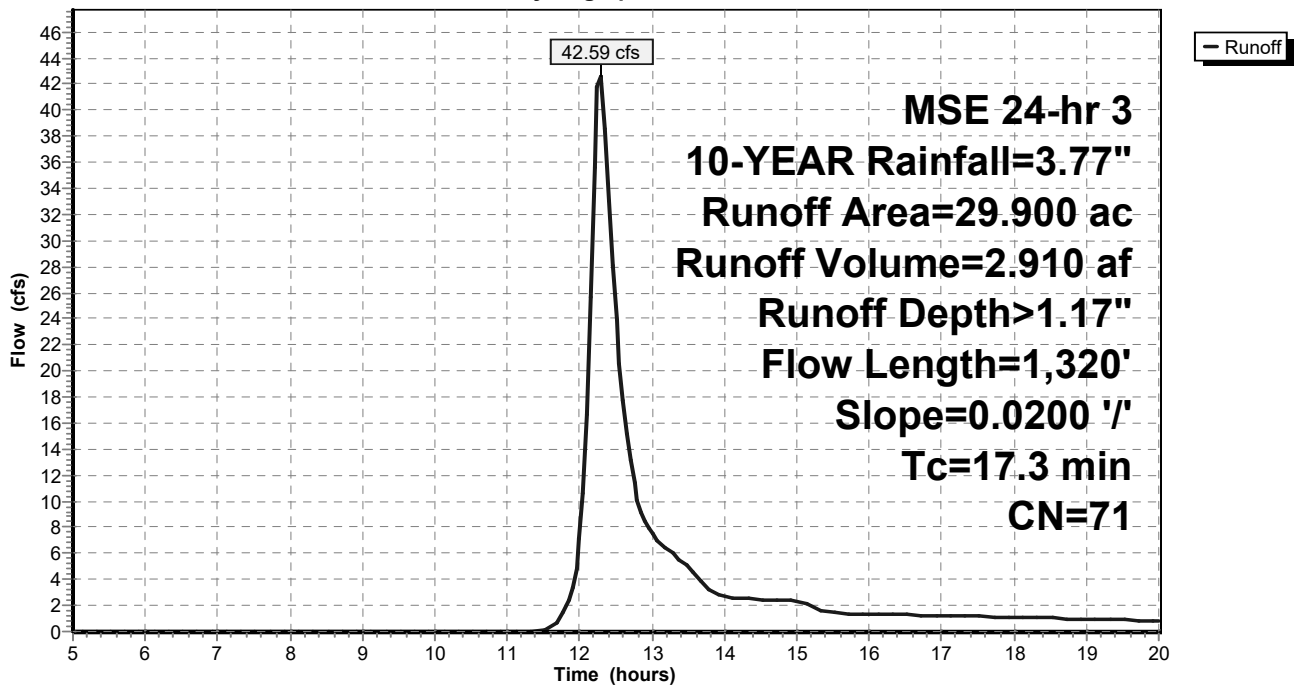

Summary for Subcatchment OFF: OFFSITE AREA

Runoff = 4.27 cfs @ 12.28 hrs, Volume= 0.292 af, Depth> 1.17"

Runoff by SCS TR-20 method, UH=SCS, Weighted-CN, Time Span= 5.00-20.00 hrs, dt= 0.05 hrs
MSE 24-hr 3 10-YEAR Rainfall=3.77"

Area (ac)	CN	Description
* 3.000	71	AG LANDS
3.000		100.00% Pervious Area

Tc (min)	Length (feet)	Slope (ft/ft)	Velocity (ft/sec)	Capacity (cfs)	Description
17.3	1,320	0.0200	1.27		Shallow Concentrated Flow, SHALLOW CONCENTRATED Cultivated Straight Rows Kv= 9.0 fps

Subcatchment OFF: OFFSITE AREA

Hydrograph

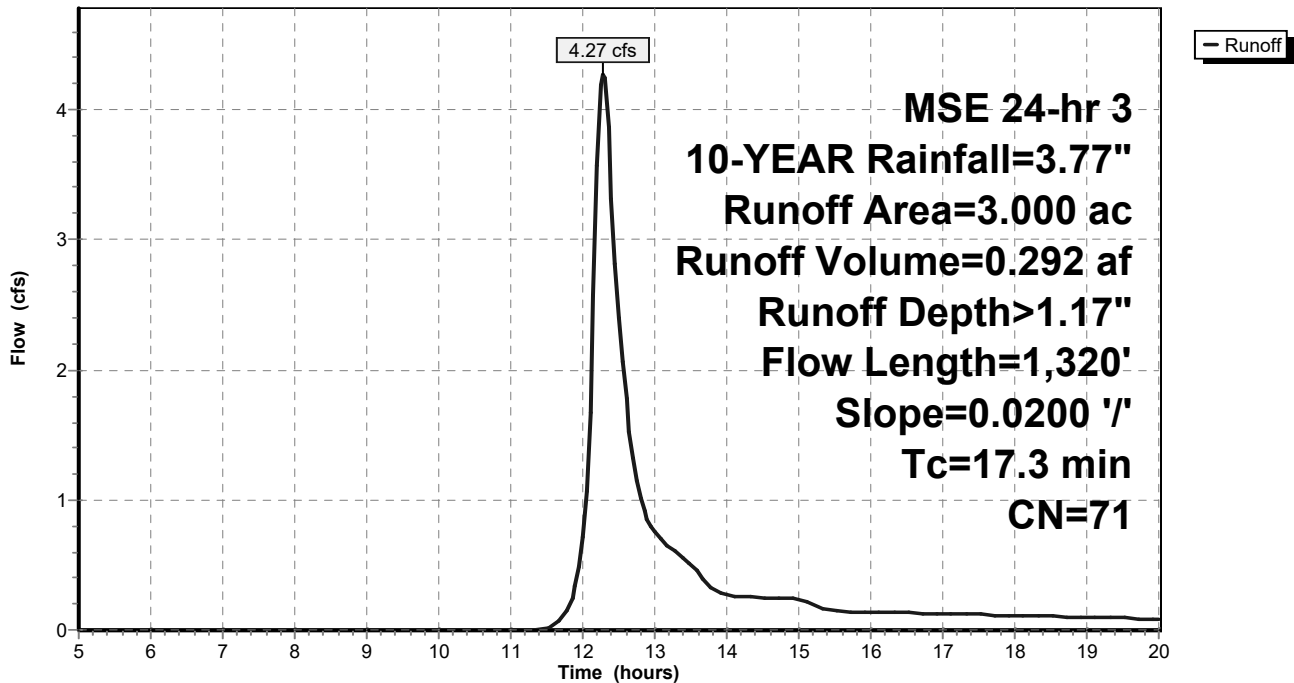

Summary for Link EAD: EXISTING ALLOWABLE DISCHARGE

Inflow Area = 32.900 ac, 0.00% Impervious, Inflow Depth > 1.17" for 10-YEAR event
Inflow = 46.87 cfs @ 12.28 hrs, Volume= 3.202 af
Primary = 46.87 cfs @ 12.28 hrs, Volume= 3.202 af, Atten= 0%, Lag= 0.0 min

Primary outflow = Inflow, Time Span= 5.00-20.00 hrs, dt= 0.05 hrs

Link EAD: EXISTING ALLOWABLE DISCHARGE

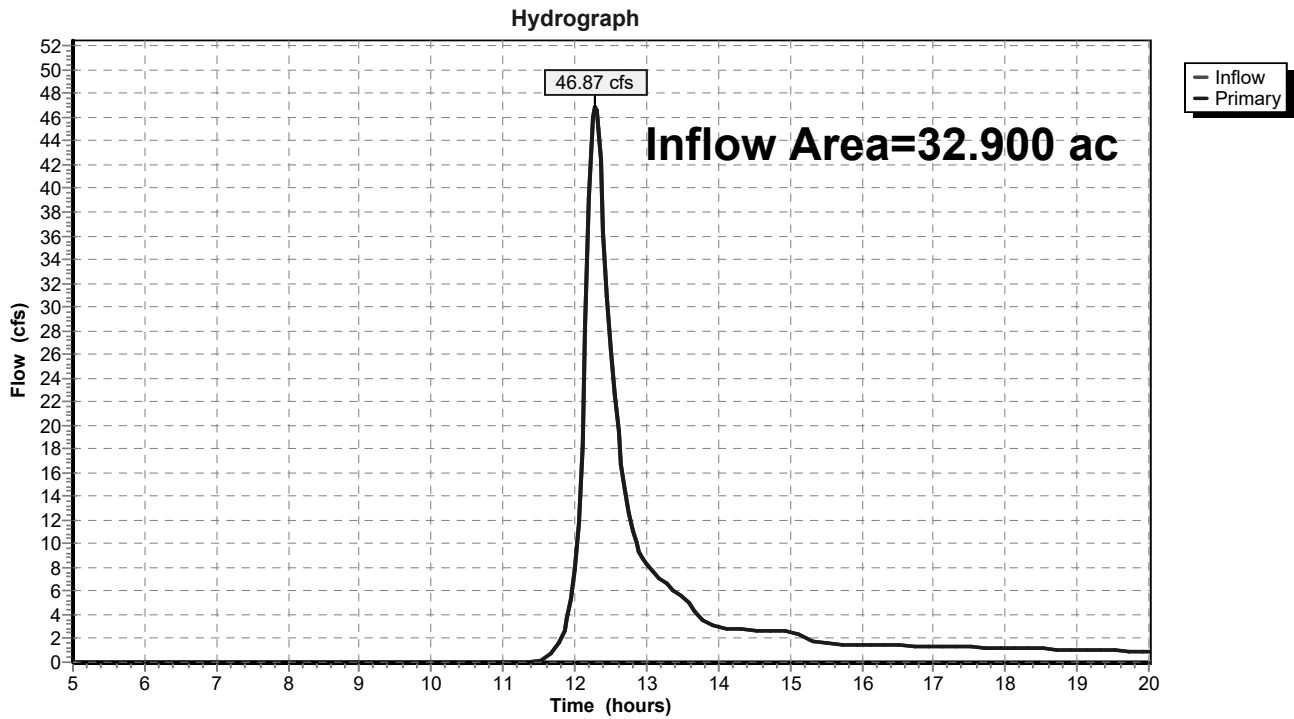

YORKVILLE

MSE 24-hr 3 100-YEAR Rainfall=5.92"

Prepared by {enter your company name here}

Printed 2/24/2021

HydroCAD® 10.00-22 s/n 07894 © 2018 HydroCAD Software Solutions LLC

Page 14

Time span=5.00-20.00 hrs, dt=0.05 hrs, 301 points
Runoff by SCS TR-20 method, UH=SCS, Weighted-CN
Reach routing by Stor-Ind+Trans method - Pond routing by Stor-Ind method

SubcatchmentES: EXISTING SITE Runoff Area=29.900 ac 0.00% Impervious Runoff Depth>2.70"
Flow Length=1,320' Slope=0.0200 '/' Tc=17.3 min CN=71 Runoff=101.75 cfs 6.724 af

SubcatchmentOFF: OFFSITE AREA Runoff Area=3.000 ac 0.00% Impervious Runoff Depth>2.70"
Flow Length=1,320' Slope=0.0200 '/' Tc=17.3 min CN=71 Runoff=10.21 cfs 0.675 af

Link EAD: EXISTING ALLOWABLE DISCHARGE Inflow=111.96 cfs 7.399 af
Primary=111.96 cfs 7.399 af

Total Runoff Area = 32.900 ac Runoff Volume = 7.399 af Average Runoff Depth = 2.70"
100.00% Pervious = 32.900 ac 0.00% Impervious = 0.000 ac

YORKVILLE

MSE 24-hr 3 100-YEAR Rainfall=5.92"

Prepared by {enter your company name here}

Printed 2/24/2021

HydroCAD® 10.00-22 s/n 07894 © 2018 HydroCAD Software Solutions LLC

Page 15

Summary for Subcatchment ES: EXISTING SITE

Runoff = 101.75 cfs @ 12.27 hrs, Volume= 6.724 af, Depth> 2.70"

Runoff by SCS TR-20 method, UH=SCS, Weighted-CN, Time Span= 5.00-20.00 hrs, dt= 0.05 hrs
MSE 24-hr 3 100-YEAR Rainfall=5.92"

Area (ac)	CN	Description
* 29.600	71	AG LANDS
* 0.300	89	GRAVEL DRIVEWAY
29.900	71	Weighted Average
29.900		100.00% Pervious Area

Tc (min)	Length (feet)	Slope (ft/ft)	Velocity (ft/sec)	Capacity (cfs)	Description
17.3	1,320	0.0200	1.27		Shallow Concentrated Flow, SHALLOW CONCENTRATED Cultivated Straight Rows Kv= 9.0 fps

Subcatchment ES: EXISTING SITE

Hydrograph

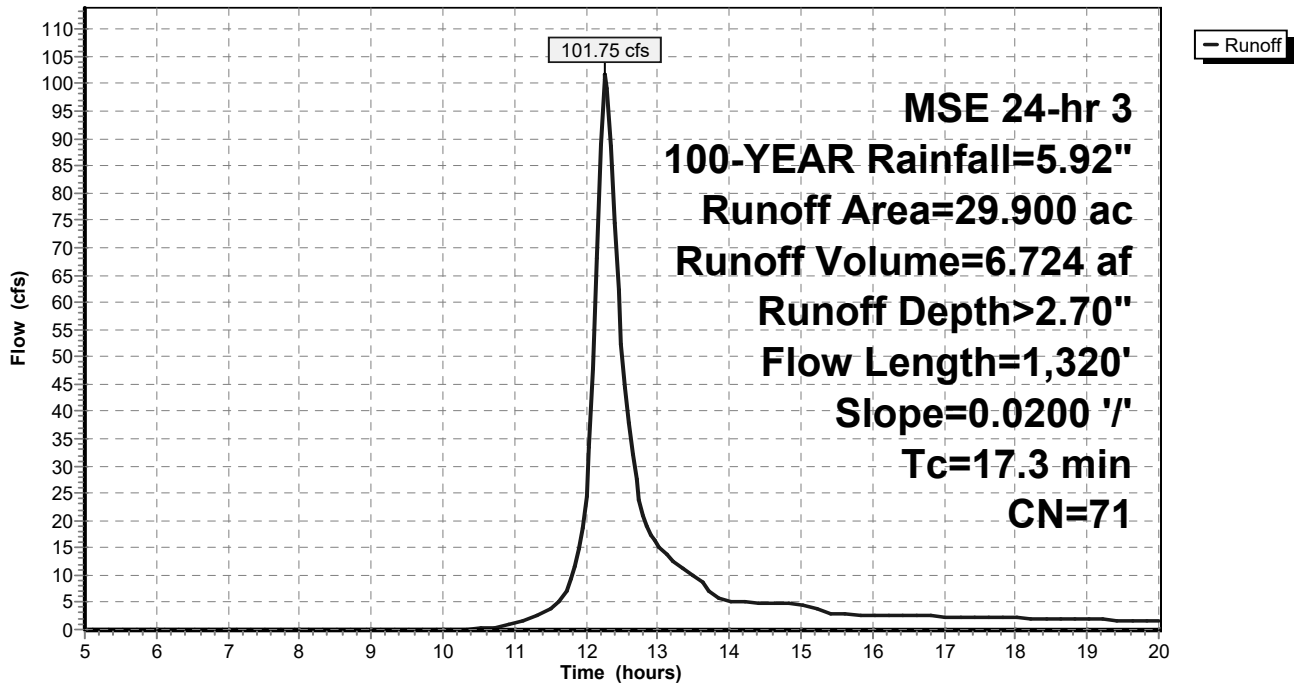

YORKVILLE

MSE 24-hr 3 100-YEAR Rainfall=5.92"

Prepared by {enter your company name here}

Printed 2/24/2021

HydroCAD® 10.00-22 s/n 07894 © 2018 HydroCAD Software Solutions LLC

Page 16

Summary for Subcatchment OFF: OFFSITE AREA

Runoff = 10.21 cfs @ 12.27 hrs, Volume= 0.675 af, Depth> 2.70"

Runoff by SCS TR-20 method, UH=SCS, Weighted-CN, Time Span= 5.00-20.00 hrs, dt= 0.05 hrs
MSE 24-hr 3 100-YEAR Rainfall=5.92"

Area (ac)	CN	Description
* 3.000	71	AG LANDS
3.000		100.00% Pervious Area

Tc (min)	Length (feet)	Slope (ft/ft)	Velocity (ft/sec)	Capacity (cfs)	Description
17.3	1,320	0.0200	1.27		Shallow Concentrated Flow, SHALLOW CONCENTRATED Cultivated Straight Rows Kv= 9.0 fps

Subcatchment OFF: OFFSITE AREA

Hydrograph

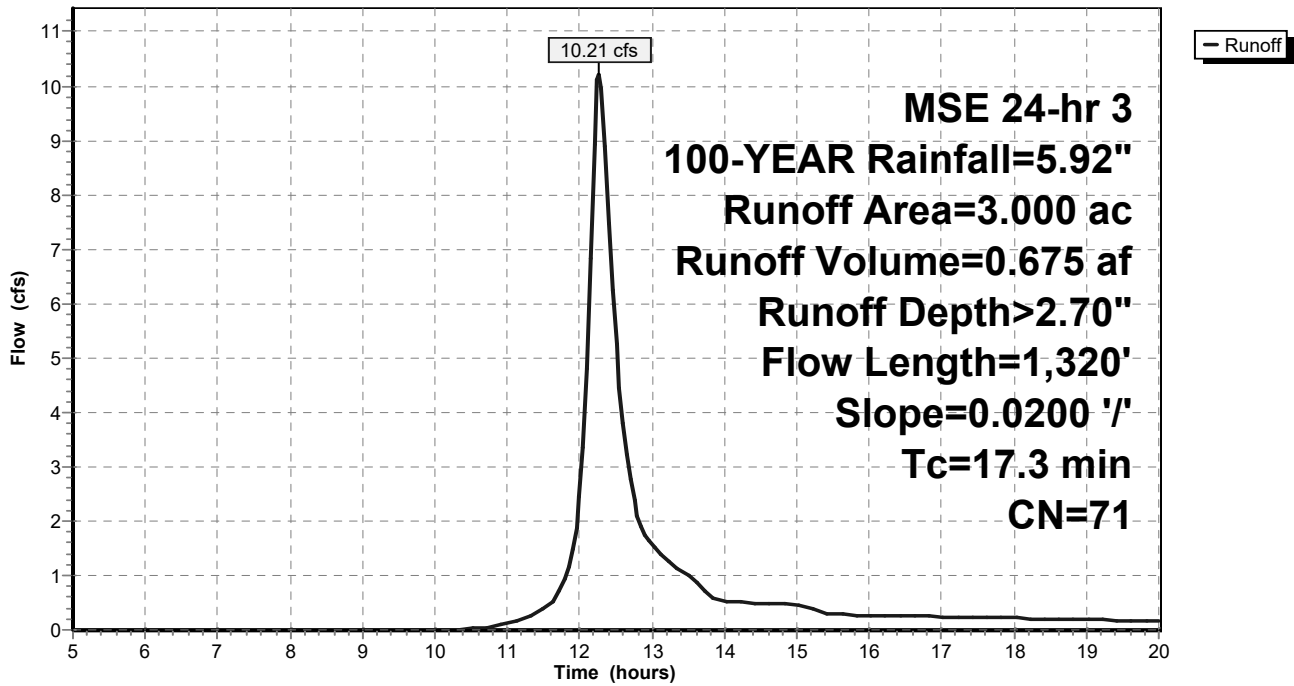

Summary for Link EAD: EXISTING ALLOWABLE DISCHARGE

Inflow Area = 32.900 ac, 0.00% Impervious, Inflow Depth > 2.70" for 100-YEAR event
Inflow = 111.96 cfs @ 12.27 hrs, Volume= 7.399 af
Primary = 111.96 cfs @ 12.27 hrs, Volume= 7.399 af, Atten= 0%, Lag= 0.0 min

Primary outflow = Inflow, Time Span= 5.00-20.00 hrs, dt= 0.05 hrs

Link EAD: EXISTING ALLOWABLE DISCHARGE

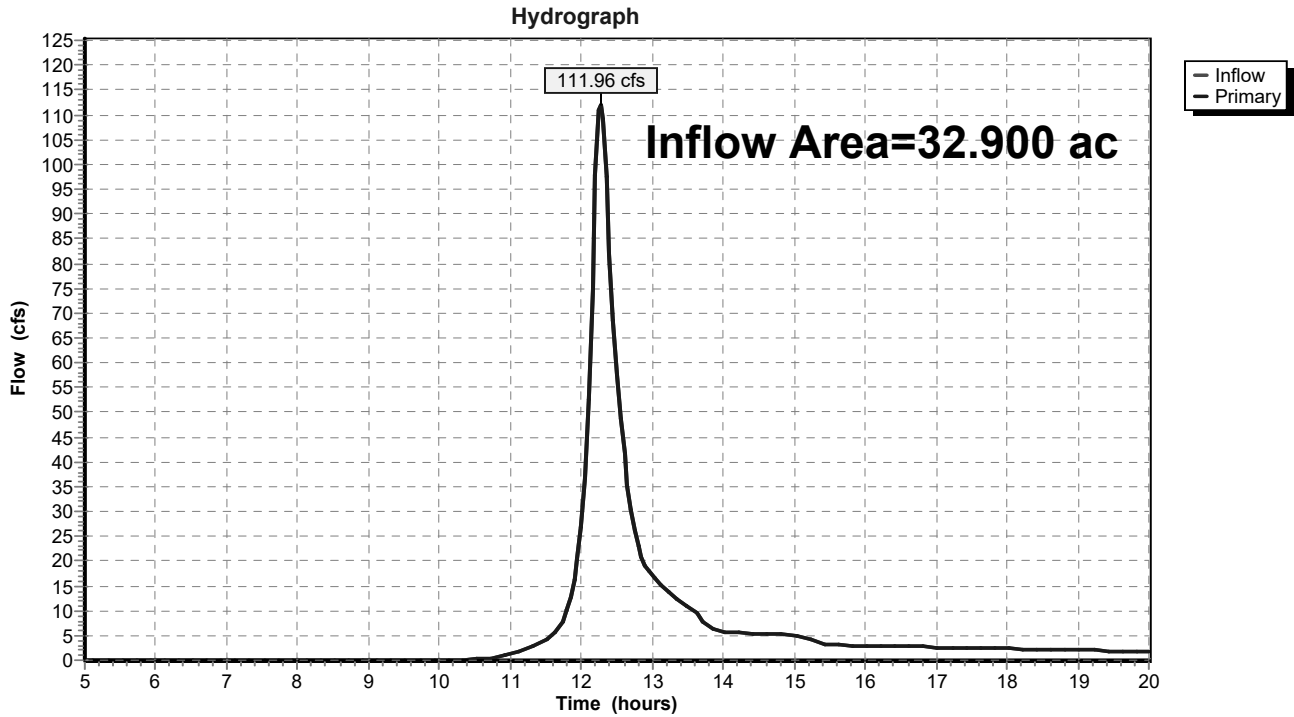

APPENDIX 3
POST-DEVELOPMENT CONDITIONS
INFORMATION (RATE ATTENUATION)

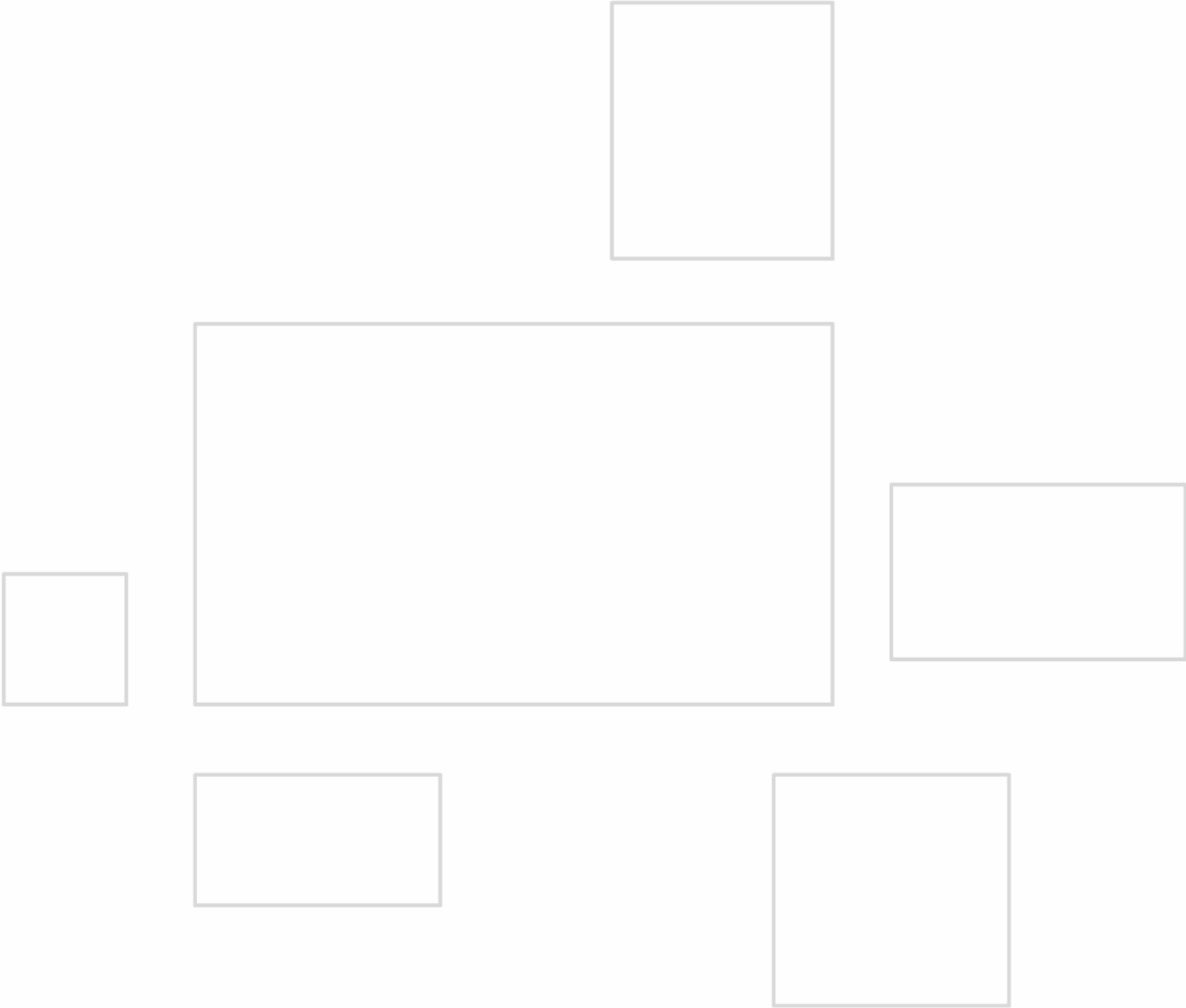

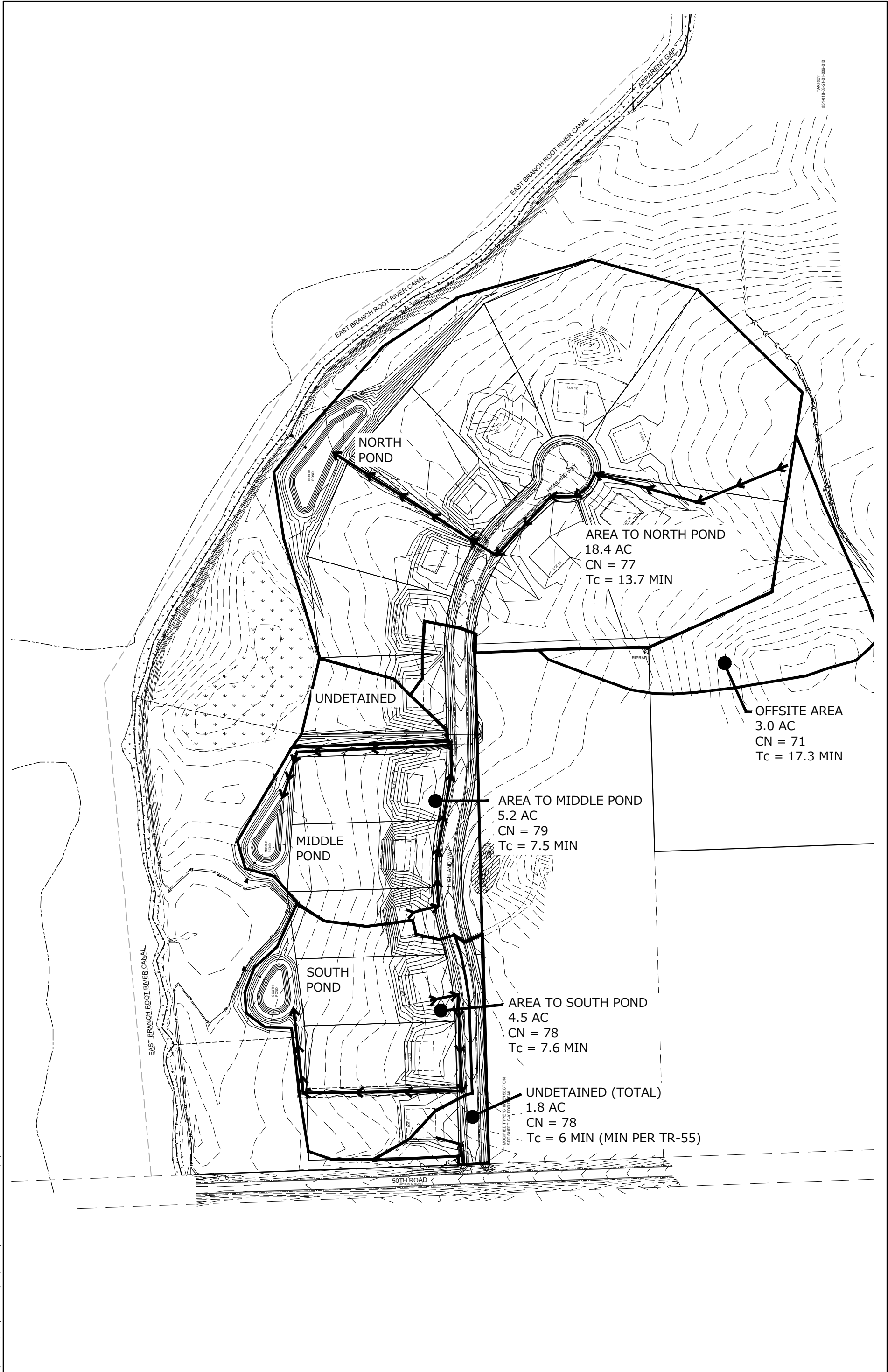

HYDROLOGY EXHIBIT - PROPOSED

100 TO 10 2 TO 2
1 TO 1

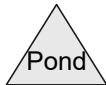
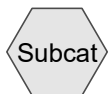
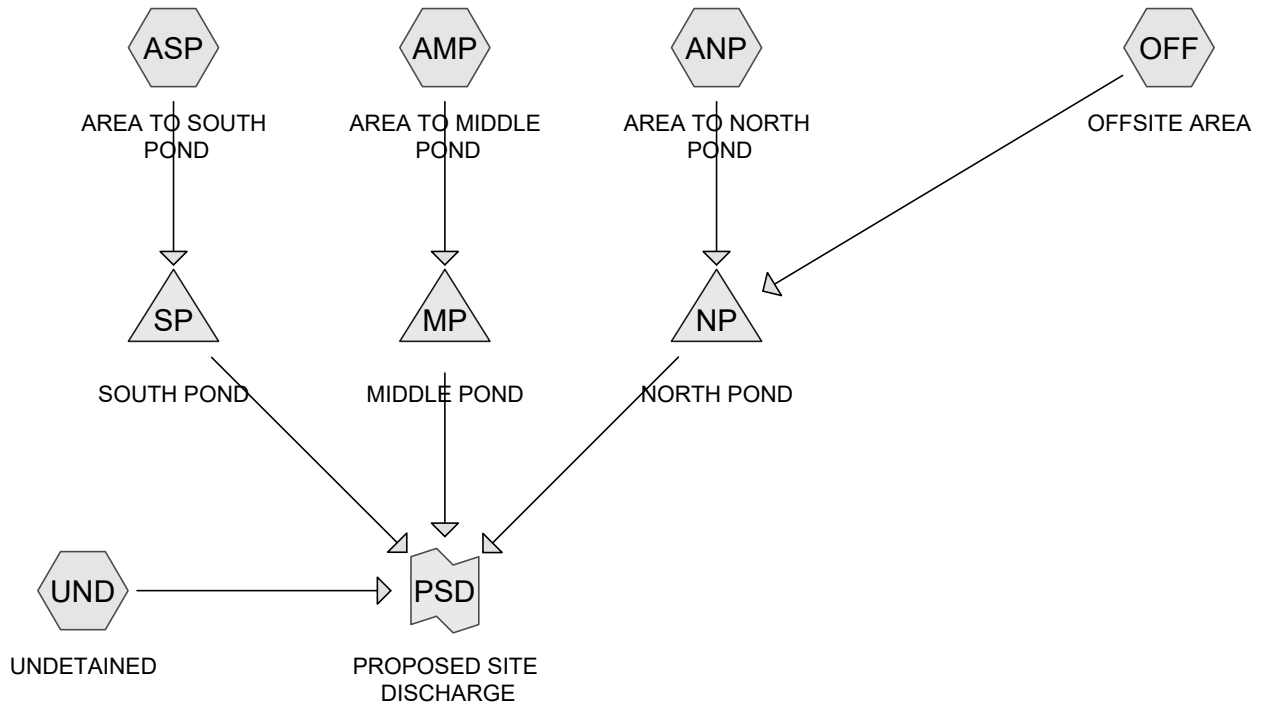

Routing Diagram for YORKVILLE

Prepared by {enter your company name here}, Printed 2/26/2021
HydroCAD® 10.00-22 s/n 07894 © 2018 HydroCAD Software Solutions LLC

YORKVILLE

MSE 24-hr 3 1-YEAR Rainfall=2.35"

Prepared by {enter your company name here}

Printed 2/26/2021

HydroCAD® 10.00-22 s/n 07894 © 2018 HydroCAD Software Solutions LLC

Page 2

Time span=5.00-20.00 hrs, dt=0.05 hrs, 301 points
 Runoff by SCS TR-20 method, UH=SCS, Weighted-CN
 Reach routing by Stor-Ind+Trans method - Pond routing by Stor-Ind method

SubcatchmentAMP: AREA TO MIDDLE Runoff Area=5.200 ac 19.23% Impervious Runoff Depth>0.70"
 Flow Length=872' Tc=7.5 min CN=79 Runoff=6.41 cfs 0.302 af

SubcatchmentANP: AREA TO NORTH Runoff Area=18.400 ac 10.87% Impervious Runoff Depth>0.61"
 Flow Length=1,190' Tc=13.7 min CN=77 Runoff=14.87 cfs 0.933 af

SubcatchmentASP: AREA TO SOUTH Runoff Area=4.500 ac 15.56% Impervious Runoff Depth>0.65"
 Flow Length=803' Tc=7.6 min CN=78 Runoff=5.10 cfs 0.245 af

SubcatchmentOFF: OFFSITE AREA Runoff Area=3.000 ac 0.00% Impervious Runoff Depth>0.39"
 Flow Length=1,320' Slope=0.0200 '/' Tc=17.3 min CN=71 Runoff=1.20 cfs 0.097 af

SubcatchmentUND: UNDETAINED Runoff Area=1.800 ac 16.67% Impervious Runoff Depth>0.65"
 Tc=6.0 min CN=78 Runoff=2.19 cfs 0.098 af

Pond MP: MIDDLE POND Peak Elev=716.75' Storage=8,084 cf Inflow=6.41 cfs 0.302 af
 Outflow=0.32 cfs 0.188 af

Pond NP: NORTH POND Peak Elev=717.09' Storage=28,457 cf Inflow=15.94 cfs 1.030 af
 Outflow=0.87 cfs 0.525 af

Pond SP: SOUTH POND Peak Elev=716.62' Storage=6,382 cf Inflow=5.10 cfs 0.245 af
 Outflow=0.28 cfs 0.160 af

Link PSD: PROPOSED SITE DISCHARGE Inflow=2.49 cfs 0.970 af
 Primary=2.49 cfs 0.970 af

Total Runoff Area = 32.900 ac Runoff Volume = 1.675 af Average Runoff Depth = 0.61"
87.84% Pervious = 28.900 ac 12.16% Impervious = 4.000 ac

YORKVILLE

MSE 24-hr 3 1-YEAR Rainfall=2.35"

Prepared by {enter your company name here}

Printed 2/26/2021

HydroCAD® 10.00-22 s/n 07894 © 2018 HydroCAD Software Solutions LLC

Page 3

Summary for Subcatchment AMP: AREA TO MIDDLE POND

Runoff = 6.41 cfs @ 12.16 hrs, Volume= 0.302 af, Depth> 0.70"

Runoff by SCS TR-20 method, UH=SCS, Weighted-CN, Time Span= 5.00-20.00 hrs, dt= 0.05 hrs
MSE 24-hr 3 1-YEAR Rainfall=2.35"

Area (ac)	CN	Description
* 0.300	98	ROOF
* 0.500	98	PAVEMENT
* 0.200	99	WATER SURFACE
* 4.200	74	GRASS
5.200	79	Weighted Average
4.200		80.77% Pervious Area
1.000		19.23% Impervious Area

Tc (min)	Length (feet)	Slope (ft/ft)	Velocity (ft/sec)	Capacity (cfs)	Description
4.9	60	0.0500	0.20		Sheet Flow, SHEET Grass: Short n= 0.150 P2= 2.67"
2.6	812	0.0150	5.16	54.22	Trap/Vee/Rect Channel Flow, Ditch Bot.W=1.00' D=1.50' Z= 4.0 '/' Top.W=13.00' n= 0.030 Earth, grassed & winding
7.5	872	Total			

Subcatchment AMP: AREA TO MIDDLE POND

Hydrograph

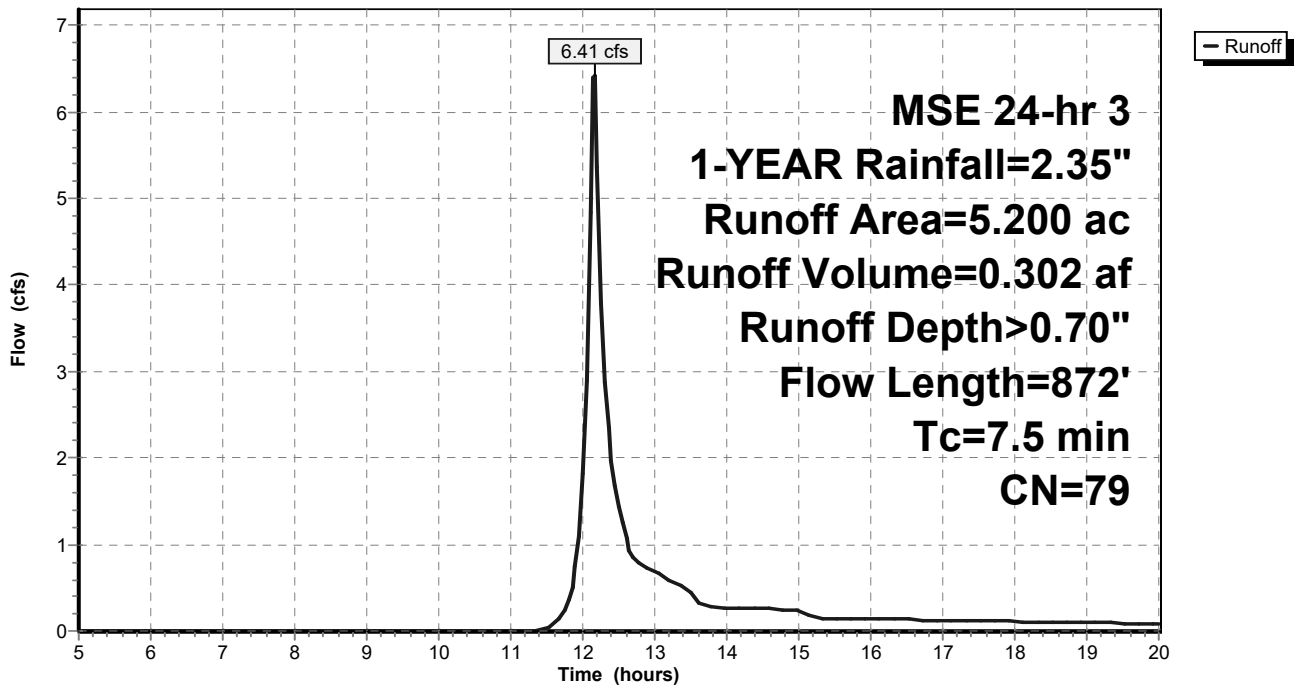

YORKVILLE

MSE 24-hr 3 1-YEAR Rainfall=2.35"

Prepared by {enter your company name here}

Printed 2/26/2021

HydroCAD® 10.00-22 s/n 07894 © 2018 HydroCAD Software Solutions LLC

Page 4

Summary for Subcatchment ANP: AREA TO NORTH POND

Runoff = 14.87 cfs @ 12.24 hrs, Volume= 0.933 af, Depth> 0.61"

Runoff by SCS TR-20 method, UH=SCS, Weighted-CN, Time Span= 5.00-20.00 hrs, dt= 0.05 hrs
MSE 24-hr 3 1-YEAR Rainfall=2.35"

Area (ac)	CN	Description
* 0.800	98	ROOF
* 0.700	98	PAVEMENT
* 0.500	99	WATER SURFACE
* 16.400	74	GRASS
18.400	77	Weighted Average
16.400		89.13% Pervious Area
2.000		10.87% Impervious Area

Tc (min)	Length (feet)	Slope (ft/ft)	Velocity (ft/sec)	Capacity (cfs)	Description
9.3	220	0.0220	0.39		Sheet Flow, Sheet Cultivated: Residue<=20% n= 0.060 P2= 2.67"
2.0	235	0.0170	1.96		Shallow Concentrated Flow, Shallow Grassed Waterway Kv= 15.0 fps
2.4	735	0.0150	5.16	54.22	Trap/Vee/Rect Channel Flow, Swale Bot.W=1.00' D=1.50' Z= 4.0 '/' Top.W=13.00' n= 0.030 Earth, grassed & winding
13.7	1,190	Total			

Subcatchment ANP: AREA TO NORTH POND

Hydrograph

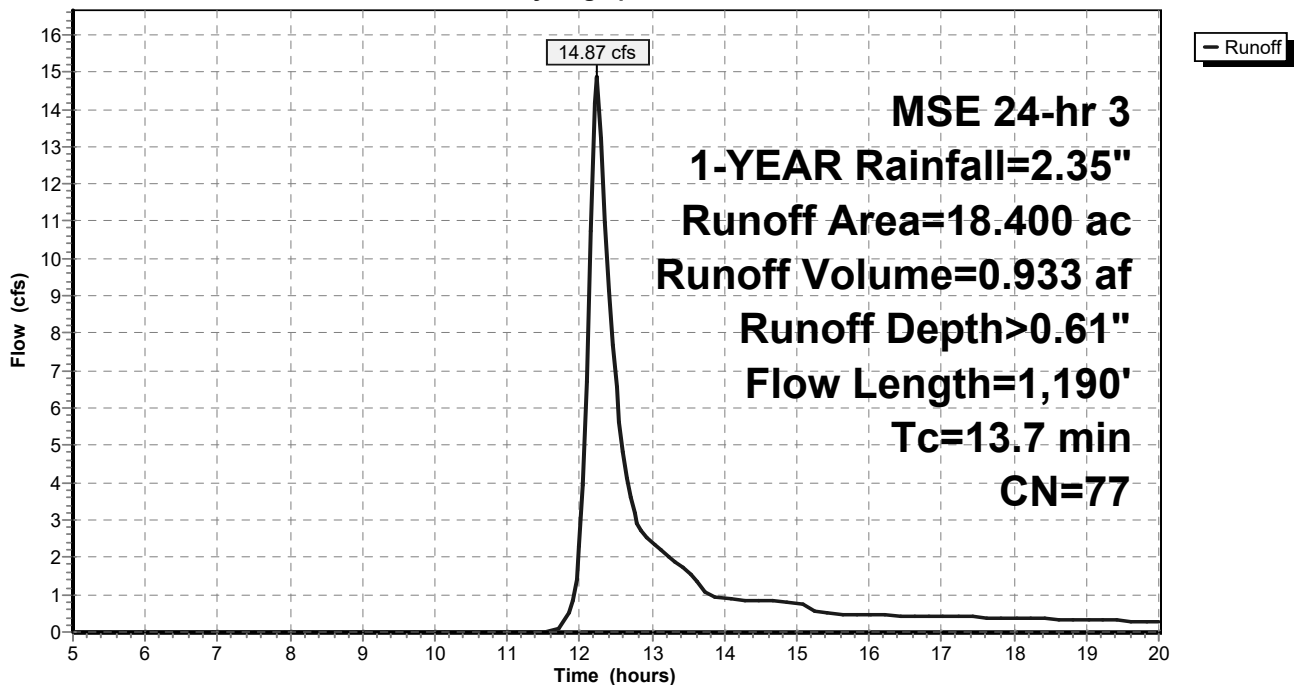

YORKVILLE

MSE 24-hr 3 1-YEAR Rainfall=2.35"

Prepared by {enter your company name here}

Printed 2/26/2021

HydroCAD® 10.00-22 s/n 07894 © 2018 HydroCAD Software Solutions LLC

Page 5

Summary for Subcatchment ASP: AREA TO SOUTH POND

Runoff = 5.10 cfs @ 12.16 hrs, Volume= 0.245 af, Depth> 0.65"

Runoff by SCS TR-20 method, UH=SCS, Weighted-CN, Time Span= 5.00-20.00 hrs, dt= 0.05 hrs
MSE 24-hr 3 1-YEAR Rainfall=2.35"

Area (ac)	CN	Description
* 0.300	98	ROOF
* 0.200	98	PAVEMENT
* 0.200	99	WATER SURFACE
* 3.800	74	GRASS
4.500	78	Weighted Average
3.800		84.44% Pervious Area
0.700		15.56% Impervious Area

Tc (min)	Length (feet)	Slope (ft/ft)	Velocity (ft/sec)	Capacity (cfs)	Description
5.2	64	0.0500	0.21		Sheet Flow, Sheet Grass: Short n= 0.150 P2= 2.67"
2.4	739	0.0150	5.16	54.22	Trap/Vee/Rect Channel Flow, Ditch Bot.W=1.00' D=1.50' Z= 4.0 '/' Top.W=13.00' n= 0.030 Earth, grassed & winding
7.6	803	Total			

Subcatchment ASP: AREA TO SOUTH POND

Hydrograph

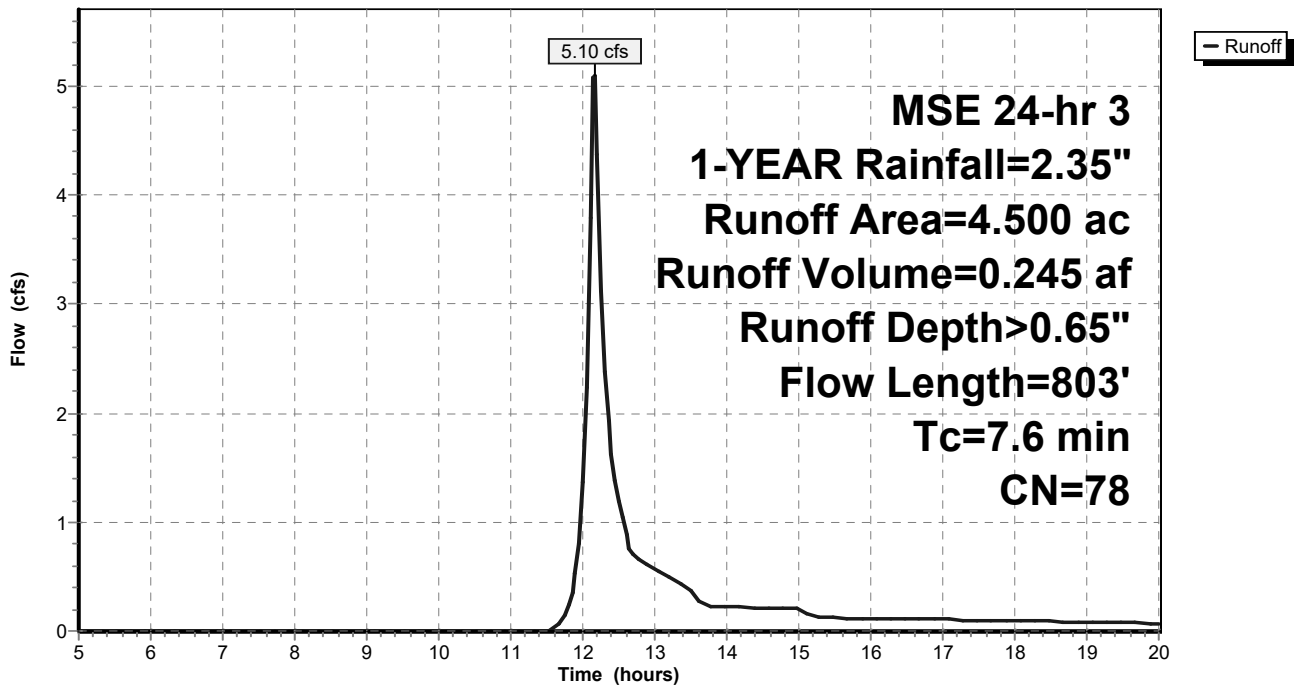

YORKVILLE

MSE 24-hr 3 1-YEAR Rainfall=2.35"

Prepared by {enter your company name here}

Printed 2/26/2021

HydroCAD® 10.00-22 s/n 07894 © 2018 HydroCAD Software Solutions LLC

Page 6

Summary for Subcatchment OFF: OFFSITE AREA

Runoff = 1.20 cfs @ 12.31 hrs, Volume= 0.097 af, Depth> 0.39"

Runoff by SCS TR-20 method, UH=SCS, Weighted-CN, Time Span= 5.00-20.00 hrs, dt= 0.05 hrs
MSE 24-hr 3 1-YEAR Rainfall=2.35"

Area (ac)	CN	Description
* 3.000	71	AG LANDS
3.000		100.00% Pervious Area

Tc (min)	Length (feet)	Slope (ft/ft)	Velocity (ft/sec)	Capacity (cfs)	Description
17.3	1,320	0.0200	1.27		Shallow Concentrated Flow, SHALLOW CONCENTRATED Cultivated Straight Rows Kv= 9.0 fps

Subcatchment OFF: OFFSITE AREA

Hydrograph

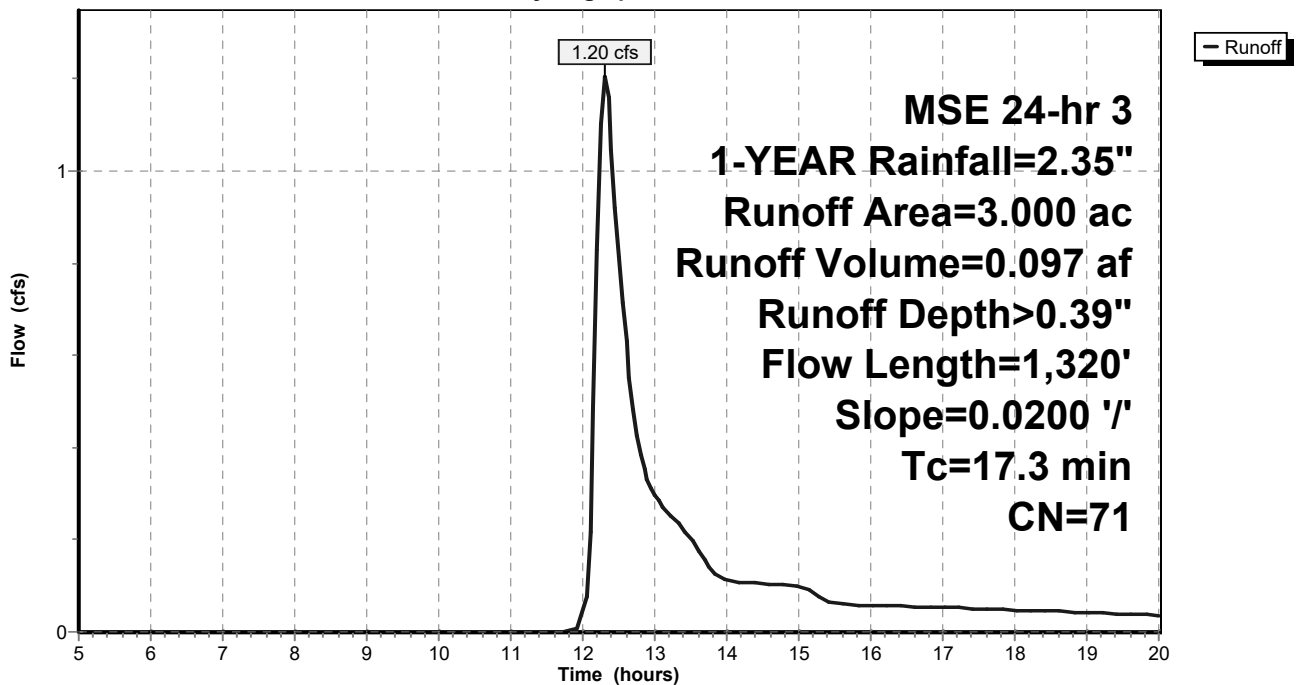

YORKVILLE

MSE 24-hr 3 1-YEAR Rainfall=2.35"

Prepared by {enter your company name here}

Printed 2/26/2021

HydroCAD® 10.00-22 s/n 07894 © 2018 HydroCAD Software Solutions LLC

Page 7

Summary for Subcatchment UND: UNDETAINED

Runoff = 2.19 cfs @ 12.14 hrs, Volume= 0.098 af, Depth> 0.65"

Runoff by SCS TR-20 method, UH=SCS, Weighted-CN, Time Span= 5.00-20.00 hrs, dt= 0.05 hrs
MSE 24-hr 3 1-YEAR Rainfall=2.35"

Area (ac)	CN	Description
* 0.100	98	ROOF
* 0.200	98	PAVEMENT
* 1.500	74	GRASS
1.800	78	Weighted Average
1.500		83.33% Pervious Area
0.300		16.67% Impervious Area

Tc (min)	Length (feet)	Slope (ft/ft)	Velocity (ft/sec)	Capacity (cfs)	Description
6.0					Direct Entry, MIN PER TR-55

Subcatchment UND: UNDETAINED

Hydrograph

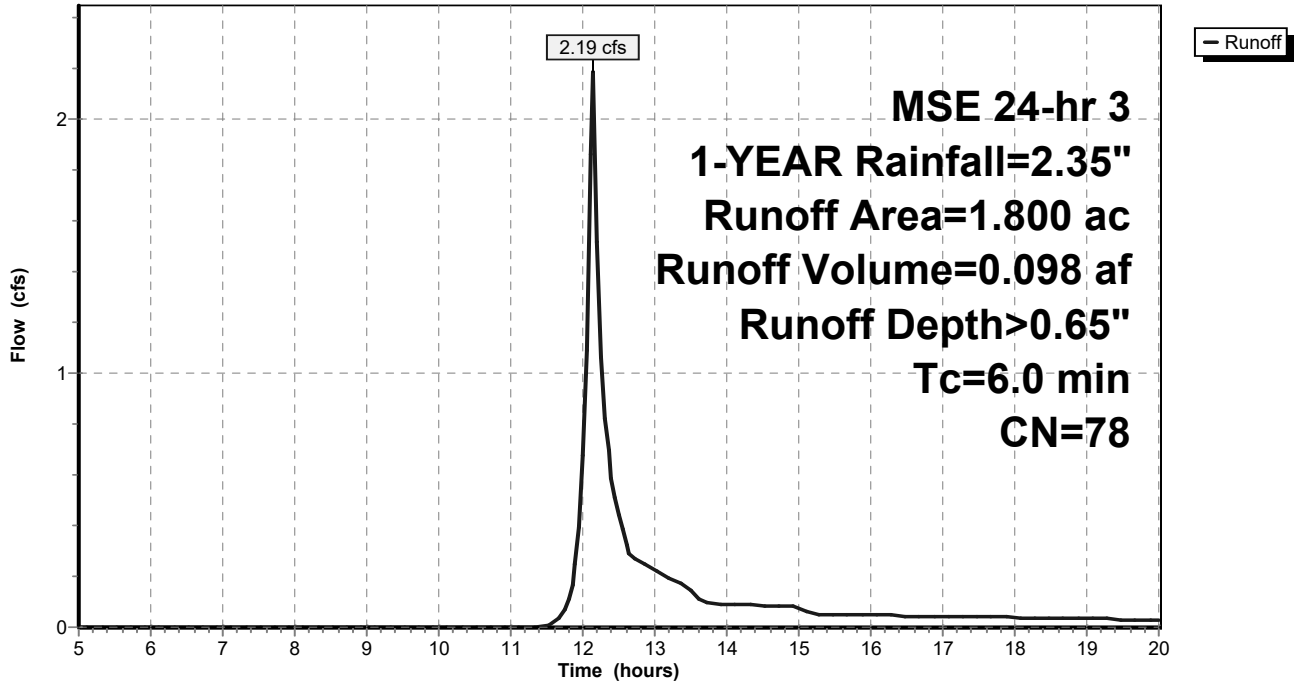

Summary for Pond MP: MIDDLE POND

Inflow Area = 5.200 ac, 19.23% Impervious, Inflow Depth > 0.70" for 1-YEAR event
 Inflow = 6.41 cfs @ 12.16 hrs, Volume= 0.302 af
 Outflow = 0.32 cfs @ 13.64 hrs, Volume= 0.188 af, Atten= 95%, Lag= 89.2 min
 Primary = 0.32 cfs @ 13.64 hrs, Volume= 0.188 af

Routing by Stor-Ind method, Time Span= 5.00-20.00 hrs, dt= 0.05 hrs
 Peak Elev= 716.75' @ 13.64 hrs Surf.Area= 11,504 sf Storage= 8,084 cf

Plug-Flow detention time= 219.5 min calculated for 0.187 af (62% of inflow)
 Center-of-Mass det. time= 151.8 min (955.6 - 803.8)

Volume	Invert	Avail.Storage	Storage Description
#1	716.00'	39,000 cf	Custom Stage Data (Prismatic) Listed below (Recalc)

Elevation (feet)	Surf.Area (sq-ft)	Inc.Store (cubic-feet)	Cum.Store (cubic-feet)
716.00	10,000	0	0
719.00	16,000	39,000	39,000

Device	Routing	Invert	Outlet Devices
#1	Primary	716.00'	12.0" Round Culvert L= 36.0' RCP, square edge headwall, Ke= 0.500 Inlet / Outlet Invert= 716.00' / 715.82' S= 0.0050 '/' Cc= 0.900 n= 0.013, Flow Area= 0.79 sf
#2	Device 1	716.00'	4.0" Vert. Orifice/Grate C= 0.600
#3	Device 1	717.00'	12.0" Horiz. Orifice/Grate C= 0.600 Limited to weir flow at low heads

Primary OutFlow Max=0.32 cfs @ 13.64 hrs HW=716.75' (Free Discharge)

- ↑ **1=Culvert** (Passes 0.32 cfs of 1.40 cfs potential flow)
- ↑ **2=Orifice/Grate** (Orifice Controls 0.32 cfs @ 3.68 fps)
- ↑ **3=Orifice/Grate** (Controls 0.00 cfs)

Pond MP: MIDDLE POND

Hydrograph

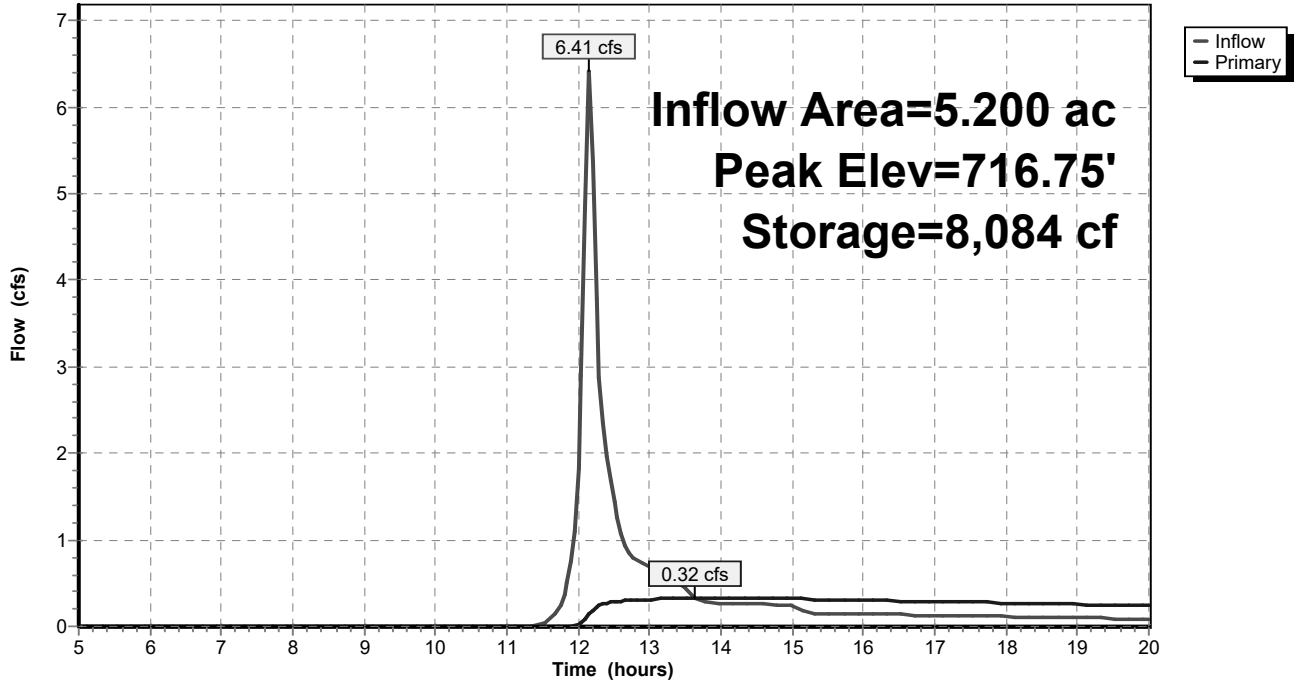

Summary for Pond NP: NORTH POND

Inflow Area = 21.400 ac, 9.35% Impervious, Inflow Depth > 0.58" for 1-YEAR event
 Inflow = 15.94 cfs @ 12.24 hrs, Volume= 1.030 af
 Outflow = 0.87 cfs @ 15.08 hrs, Volume= 0.525 af, Atten= 95%, Lag= 170.4 min
 Primary = 0.87 cfs @ 15.08 hrs, Volume= 0.525 af

Routing by Stor-Ind method, Time Span= 5.00-20.00 hrs, dt= 0.05 hrs
 Peak Elev= 717.09' @ 15.08 hrs Surf.Area= 30,023 sf Storage= 28,457 cf

Plug-Flow detention time= 227.7 min calculated for 0.523 af (51% of inflow)
 Center-of-Mass det. time= 151.8 min (966.7 - 814.9)

Volume	Invert	Avail.Storage	Storage Description
#1	716.00'	146,000 cf	Custom Stage Data (Prismatic) Listed below (Recalc)
Elevation (feet)	Surf.Area (sq-ft)	Inc.Store (cubic-feet)	Cum.Store (cubic-feet)
716.00	22,000	0	0
719.00	44,000	99,000	99,000
720.00	50,000	47,000	146,000

Device	Routing	Invert	Outlet Devices
#1	Primary	716.00'	24.0" Round Culvert L= 36.0' RCP, square edge headwall, Ke= 0.500 Inlet / Outlet Invert= 716.00' / 715.82' S= 0.0050 '/' Cc= 0.900 n= 0.013, Flow Area= 3.14 sf
#2	Device 1	716.00'	6.0" Vert. Orifice/Grate C= 0.600
#3	Device 1	717.50'	36.0" Vert. Orifice/Grate C= 0.600

Primary OutFlow Max=0.87 cfs @ 15.08 hrs HW=717.09' (Free Discharge)

- ↑ **1=Culvert** (Passes 0.87 cfs of 4.59 cfs potential flow)
- ↑ **2=Orifice/Grate** (Orifice Controls 0.87 cfs @ 4.42 fps)
- ↑ **3=Orifice/Grate** (Controls 0.00 cfs)

Pond NP: NORTH POND

Hydrograph

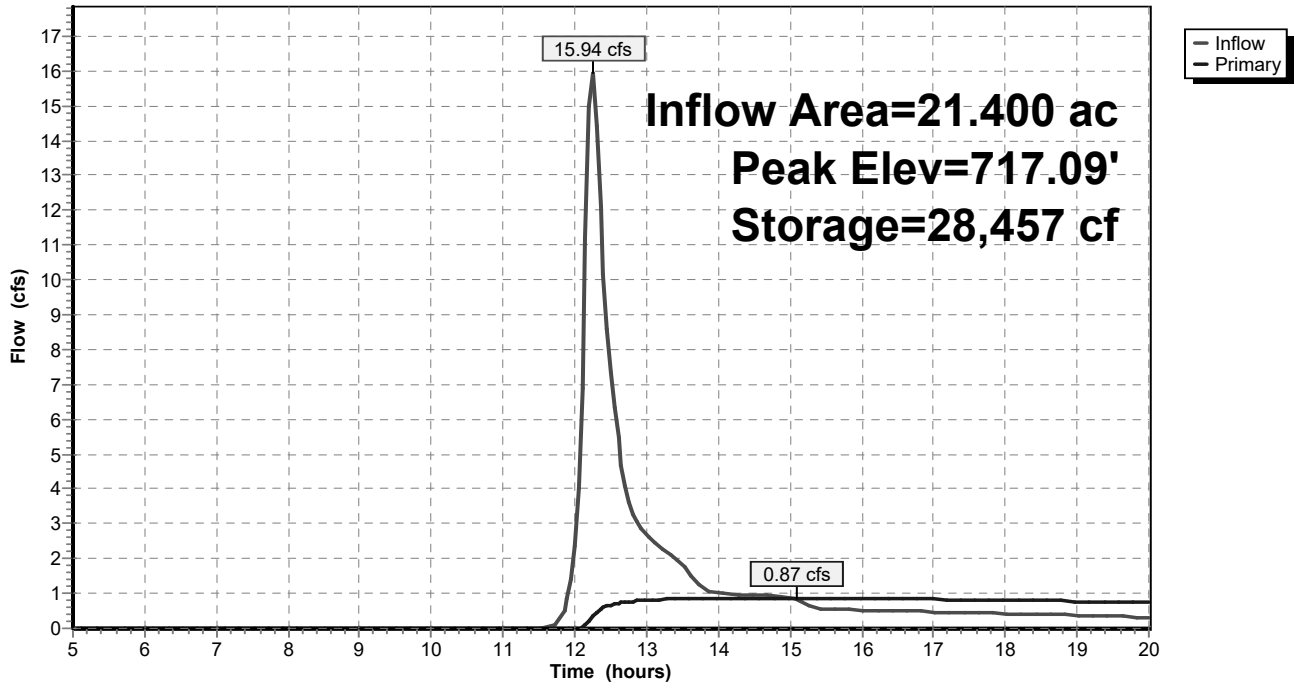

Summary for Pond SP: SOUTH POND

Inflow Area = 4.500 ac, 15.56% Impervious, Inflow Depth > 0.65" for 1-YEAR event
 Inflow = 5.10 cfs @ 12.16 hrs, Volume= 0.245 af
 Outflow = 0.28 cfs @ 13.62 hrs, Volume= 0.160 af, Atten= 94%, Lag= 87.8 min
 Primary = 0.28 cfs @ 13.62 hrs, Volume= 0.160 af

Routing by Stor-Ind method, Time Span= 5.00-20.00 hrs, dt= 0.05 hrs
 Peak Elev= 716.62' @ 13.62 hrs Surf.Area= 10,851 sf Storage= 6,382 cf

Plug-Flow detention time= 214.0 min calculated for 0.160 af (65% of inflow)
 Center-of-Mass det. time= 146.7 min (952.9 - 806.1)

Volume	Invert	Avail.Storage	Storage Description
#1	716.00'	37,050 cf	Custom Stage Data (Prismatic) Listed below (Recalc)

Elevation (feet)	Surf.Area (sq-ft)	Inc.Store (cubic-feet)	Cum.Store (cubic-feet)
716.00	9,800	0	0
719.00	14,900	37,050	37,050

Device	Routing	Invert	Outlet Devices
#1	Primary	716.00'	12.0" Round Culvert L= 36.0' RCP, square edge headwall, Ke= 0.500 Inlet / Outlet Invert= 716.00' / 715.82' S= 0.0050 '/' Cc= 0.900 n= 0.013, Flow Area= 0.79 sf
#2	Device 1	716.00'	4.0" Vert. Orifice/Grate C= 0.600
#3	Device 1	717.00'	12.0" Horiz. Orifice/Grate C= 0.600 Limited to weir flow at low heads

Primary OutFlow Max=0.28 cfs @ 13.62 hrs HW=716.62' (Free Discharge)

- ↑ **1=Culvert** (Passes 0.28 cfs of 1.00 cfs potential flow)
- ↑ **2=Orifice/Grate** (Orifice Controls 0.28 cfs @ 3.23 fps)
- ↑ **3=Orifice/Grate** (Controls 0.00 cfs)

Pond SP: SOUTH POND

Hydrograph

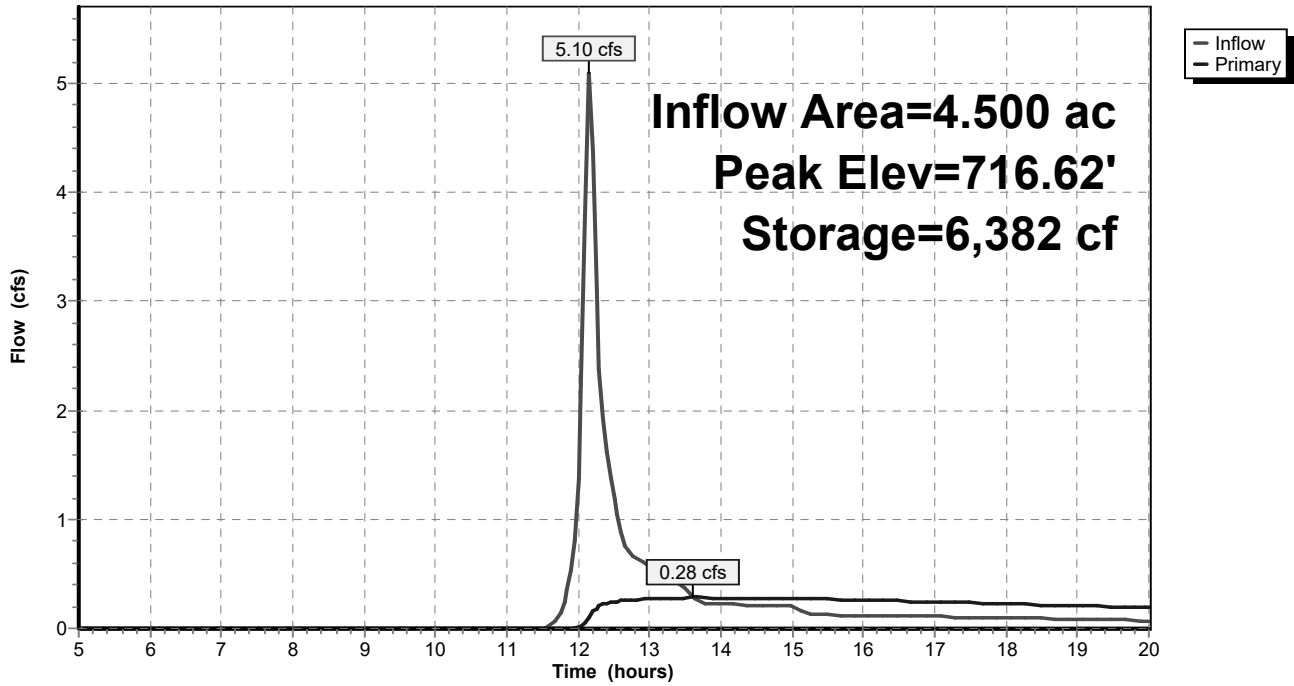

Summary for Link PSD: PROPOSED SITE DISCHARGE

Inflow Area = 32.900 ac, 12.16% Impervious, Inflow Depth > 0.35" for 1-YEAR event
Inflow = 2.49 cfs @ 12.15 hrs, Volume= 0.970 af
Primary = 2.49 cfs @ 12.15 hrs, Volume= 0.970 af, Atten= 0%, Lag= 0.0 min

Primary outflow = Inflow, Time Span= 5.00-20.00 hrs, dt= 0.05 hrs

Link PSD: PROPOSED SITE DISCHARGE

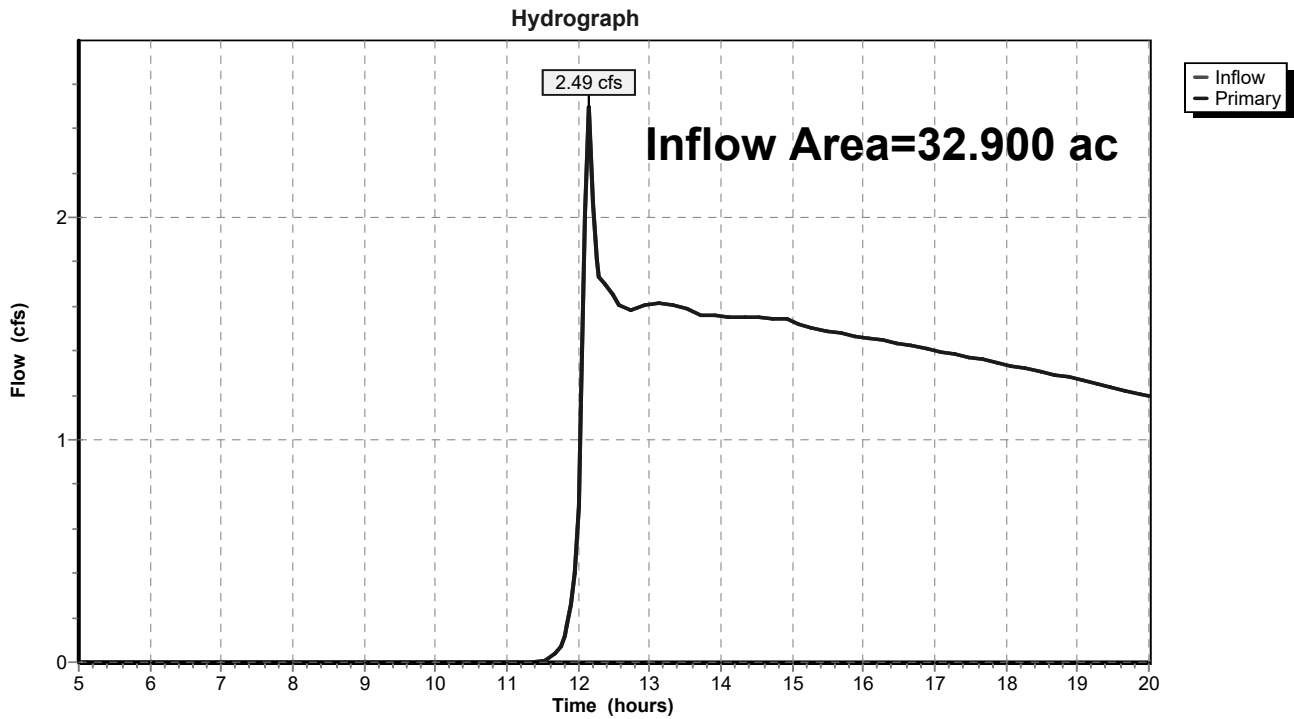

YORKVILLE

MSE 24-hr 3 2-YEAR Rainfall=2.67"

Prepared by {enter your company name here}

Printed 2/26/2021

HydroCAD® 10.00-22 s/n 07894 © 2018 HydroCAD Software Solutions LLC

Page 15

Time span=5.00-20.00 hrs, dt=0.05 hrs, 301 points
 Runoff by SCS TR-20 method, UH=SCS, Weighted-CN
 Reach routing by Stor-Ind+Trans method - Pond routing by Stor-Ind method

SubcatchmentAMP: AREA TO MIDDLE Runoff Area=5.200 ac 19.23% Impervious Runoff Depth>0.90"
 Flow Length=872' Tc=7.5 min CN=79 Runoff=8.39 cfs 0.392 af

SubcatchmentANP: AREA TO NORTH Runoff Area=18.400 ac 10.87% Impervious Runoff Depth>0.80"
 Flow Length=1,190' Tc=13.7 min CN=77 Runoff=20.01 cfs 1.228 af

SubcatchmentASP: AREA TO SOUTH Runoff Area=4.500 ac 15.56% Impervious Runoff Depth>0.85"
 Flow Length=803' Tc=7.6 min CN=78 Runoff=6.74 cfs 0.319 af

SubcatchmentOFF: OFFSITE AREA Runoff Area=3.000 ac 0.00% Impervious Runoff Depth>0.54"
 Flow Length=1,320' Slope=0.0200 '/' Tc=17.3 min CN=71 Runoff=1.80 cfs 0.135 af

SubcatchmentUND: UNDETAINED Runoff Area=1.800 ac 16.67% Impervious Runoff Depth>0.85"
 Tc=6.0 min CN=78 Runoff=2.88 cfs 0.128 af

Pond MP: MIDDLE POND Peak Elev=716.99' Storage=10,835 cf Inflow=8.39 cfs 0.392 af
 Outflow=0.38 cfs 0.228 af

Pond NP: NORTH POND Peak Elev=717.44' Storage=39,266 cf Inflow=21.64 cfs 1.362 af
 Outflow=1.03 cfs 0.633 af

Pond SP: SOUTH POND Peak Elev=716.82' Storage=8,625 cf Inflow=6.74 cfs 0.319 af
 Outflow=0.34 cfs 0.199 af

Link PSD: PROPOSED SITE DISCHARGE Inflow=3.42 cfs 1.188 af
 Primary=3.42 cfs 1.188 af

Total Runoff Area = 32.900 ac Runoff Volume = 2.201 af Average Runoff Depth = 0.80"
87.84% Pervious = 28.900 ac 12.16% Impervious = 4.000 ac

YORKVILLE

MSE 24-hr 3 2-YEAR Rainfall=2.67"

Prepared by {enter your company name here}

Printed 2/26/2021

HydroCAD® 10.00-22 s/n 07894 © 2018 HydroCAD Software Solutions LLC

Page 16

Summary for Subcatchment AMP: AREA TO MIDDLE POND

Runoff = 8.39 cfs @ 12.15 hrs, Volume= 0.392 af, Depth> 0.90"

Runoff by SCS TR-20 method, UH=SCS, Weighted-CN, Time Span= 5.00-20.00 hrs, dt= 0.05 hrs
MSE 24-hr 3 2-YEAR Rainfall=2.67"

Area (ac)	CN	Description
* 0.300	98	ROOF
* 0.500	98	PAVEMENT
* 0.200	99	WATER SURFACE
* 4.200	74	GRASS
5.200	79	Weighted Average
4.200		80.77% Pervious Area
1.000		19.23% Impervious Area

Tc (min)	Length (feet)	Slope (ft/ft)	Velocity (ft/sec)	Capacity (cfs)	Description
4.9	60	0.0500	0.20		Sheet Flow, SHEET Grass: Short n= 0.150 P2= 2.67"
2.6	812	0.0150	5.16	54.22	Trap/Vee/Rect Channel Flow, Ditch Bot.W=1.00' D=1.50' Z= 4.0 '/' Top.W=13.00' n= 0.030 Earth, grassed & winding
7.5	872	Total			

Subcatchment AMP: AREA TO MIDDLE POND

Hydrograph

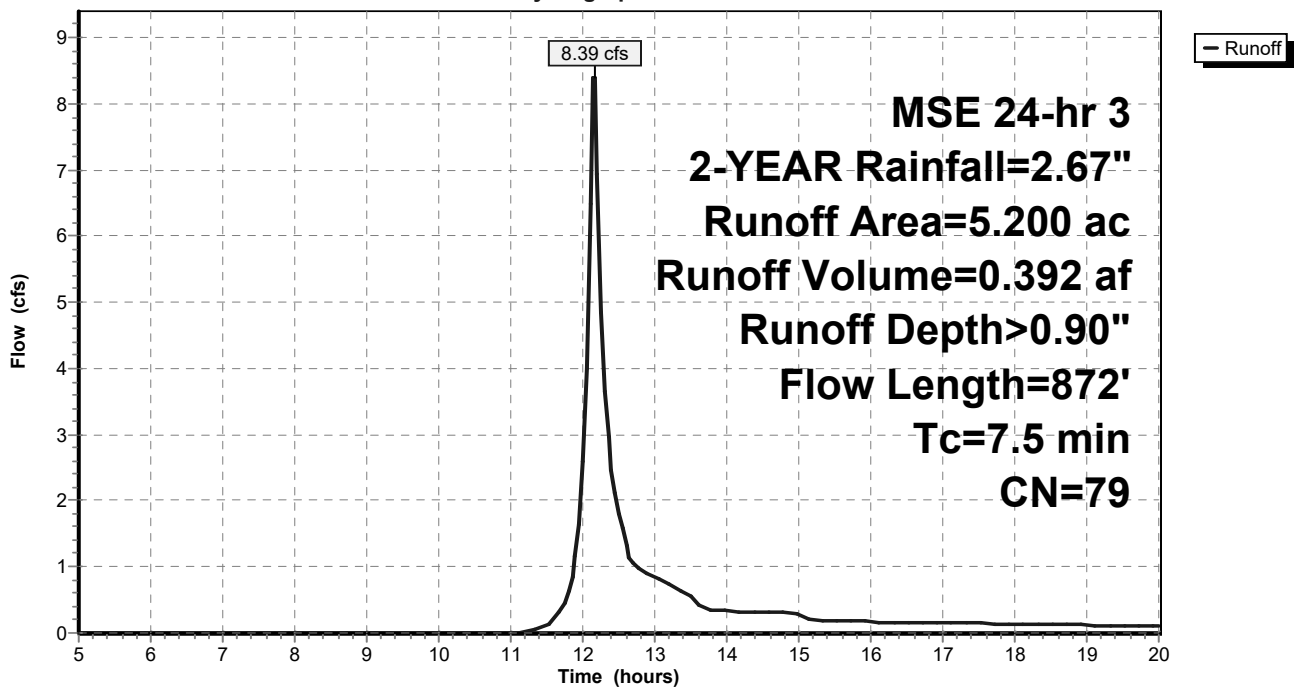

Summary for Subcatchment ANP: AREA TO NORTH POND

Runoff = 20.01 cfs @ 12.23 hrs, Volume= 1.228 af, Depth> 0.80"

Runoff by SCS TR-20 method, UH=SCS, Weighted-CN, Time Span= 5.00-20.00 hrs, dt= 0.05 hrs
MSE 24-hr 3 2-YEAR Rainfall=2.67"

Area (ac)	CN	Description
* 0.800	98	ROOF
* 0.700	98	PAVEMENT
* 0.500	99	WATER SURFACE
* 16.400	74	GRASS
18.400	77	Weighted Average
16.400		89.13% Pervious Area
2.000		10.87% Impervious Area

Tc (min)	Length (feet)	Slope (ft/ft)	Velocity (ft/sec)	Capacity (cfs)	Description
9.3	220	0.0220	0.39		Sheet Flow, Sheet Cultivated: Residue<=20% n= 0.060 P2= 2.67"
2.0	235	0.0170	1.96		Shallow Concentrated Flow, Shallow Grassed Waterway Kv= 15.0 fps
2.4	735	0.0150	5.16	54.22	Trap/Vee/Rect Channel Flow, Swale Bot.W=1.00' D=1.50' Z= 4.0 '/' Top.W=13.00' n= 0.030 Earth, grassed & winding
13.7	1,190	Total			

Subcatchment ANP: AREA TO NORTH POND

Hydrograph

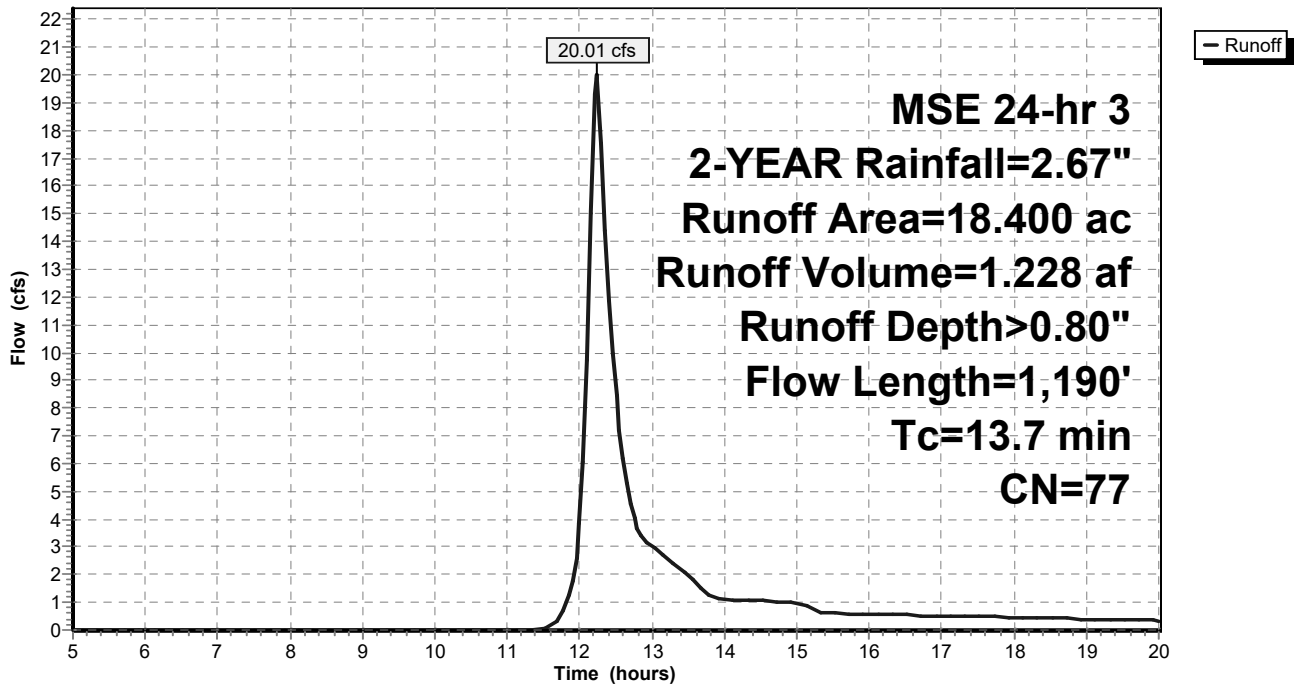

YORKVILLE

Prepared by {enter your company name here}

HydroCAD® 10.00-22 s/n 07894 © 2018 HydroCAD Software Solutions LLC

MSE 24-hr 3 2-YEAR Rainfall=2.67"

Printed 2/26/2021

Page 18

Summary for Subcatchment ASP: AREA TO SOUTH POND

Runoff = 6.74 cfs @ 12.16 hrs, Volume= 0.319 af, Depth> 0.85"

Runoff by SCS TR-20 method, UH=SCS, Weighted-CN, Time Span= 5.00-20.00 hrs, dt= 0.05 hrs
MSE 24-hr 3 2-YEAR Rainfall=2.67"

Area (ac)	CN	Description
* 0.300	98	ROOF
* 0.200	98	PAVEMENT
* 0.200	99	WATER SURFACE
* 3.800	74	GRASS
4.500	78	Weighted Average
3.800		84.44% Pervious Area
0.700		15.56% Impervious Area

Tc (min)	Length (feet)	Slope (ft/ft)	Velocity (ft/sec)	Capacity (cfs)	Description
5.2	64	0.0500	0.21		Sheet Flow, Sheet Grass: Short n= 0.150 P2= 2.67"
2.4	739	0.0150	5.16	54.22	Trap/Vee/Rect Channel Flow, Ditch Bot.W=1.00' D=1.50' Z= 4.0 '/' Top.W=13.00' n= 0.030 Earth, grassed & winding
7.6	803	Total			

Subcatchment ASP: AREA TO SOUTH POND

Hydrograph

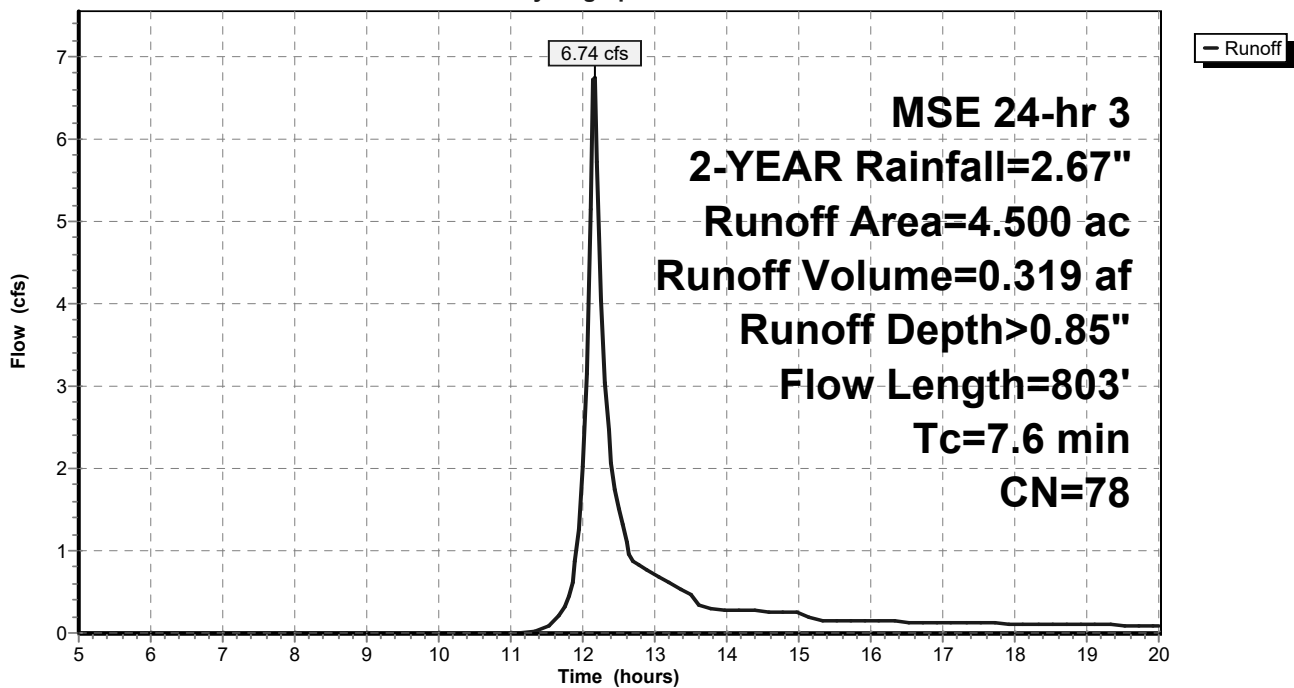

Summary for Subcatchment OFF: OFFSITE AREA

Runoff = 1.80 cfs @ 12.30 hrs, Volume= 0.135 af, Depth> 0.54"

Runoff by SCS TR-20 method, UH=SCS, Weighted-CN, Time Span= 5.00-20.00 hrs, dt= 0.05 hrs
MSE 24-hr 3 2-YEAR Rainfall=2.67"

Area (ac)	CN	Description
* 3.000	71	AG LANDS
3.000		100.00% Pervious Area

Tc (min)	Length (feet)	Slope (ft/ft)	Velocity (ft/sec)	Capacity (cfs)	Description
17.3	1,320	0.0200	1.27		Shallow Concentrated Flow, SHALLOW CONCENTRATED Cultivated Straight Rows Kv= 9.0 fps

Subcatchment OFF: OFFSITE AREA

Hydrograph

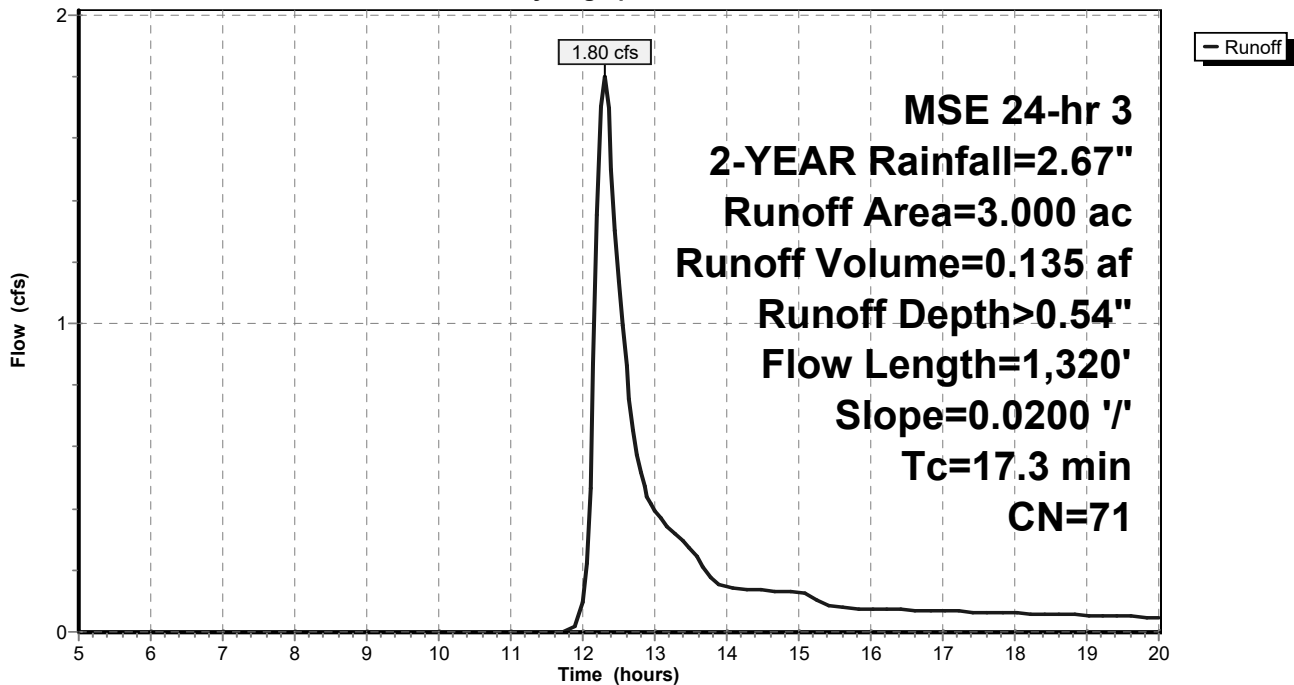

YORKVILLE

MSE 24-hr 3 2-YEAR Rainfall=2.67"

Prepared by {enter your company name here}

Printed 2/26/2021

HydroCAD® 10.00-22 s/n 07894 © 2018 HydroCAD Software Solutions LLC

Page 20

Summary for Subcatchment UND: UNDETAINED

Runoff = 2.88 cfs @ 12.14 hrs, Volume= 0.128 af, Depth> 0.85"

Runoff by SCS TR-20 method, UH=SCS, Weighted-CN, Time Span= 5.00-20.00 hrs, dt= 0.05 hrs
 MSE 24-hr 3 2-YEAR Rainfall=2.67"

Area (ac)	CN	Description
* 0.100	98	ROOF
* 0.200	98	PAVEMENT
* 1.500	74	GRASS
1.800	78	Weighted Average
1.500		83.33% Pervious Area
0.300		16.67% Impervious Area

Tc (min)	Length (feet)	Slope (ft/ft)	Velocity (ft/sec)	Capacity (cfs)	Description
6.0					Direct Entry, MIN PER TR-55

Subcatchment UND: UNDETAINED

Hydrograph

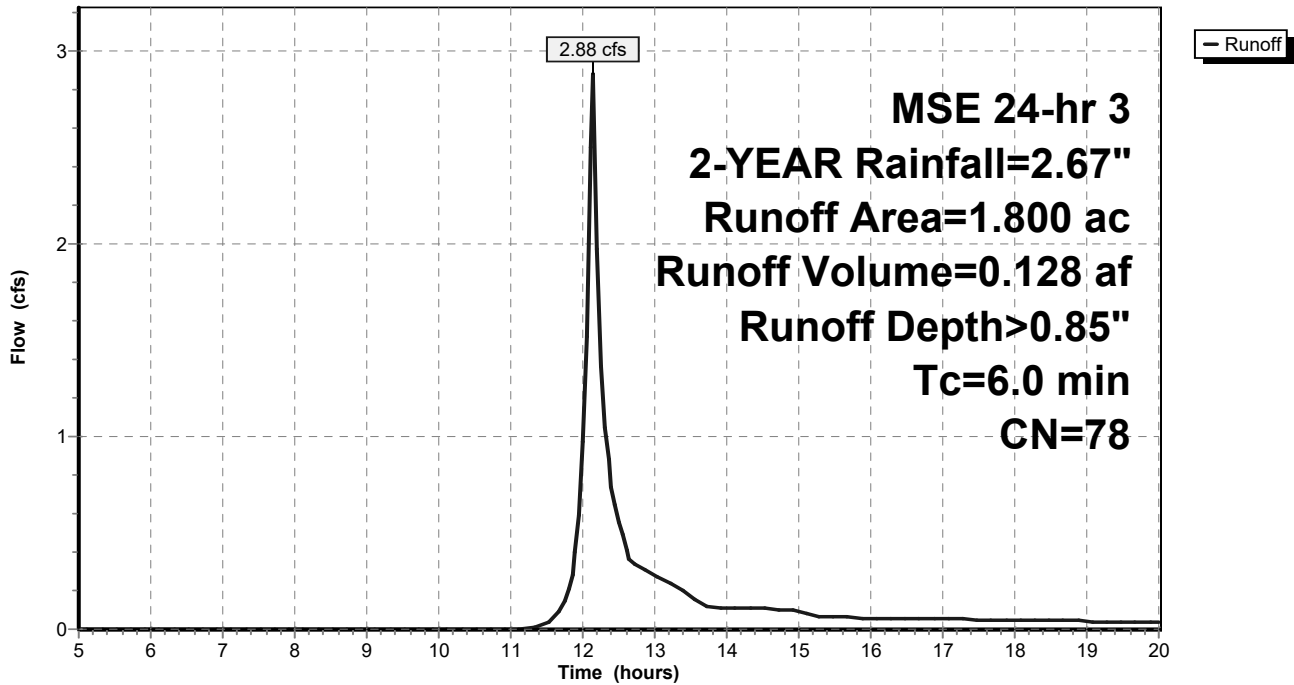

Summary for Pond MP: MIDDLE POND

Inflow Area = 5.200 ac, 19.23% Impervious, Inflow Depth > 0.90" for 2-YEAR event
 Inflow = 8.39 cfs @ 12.15 hrs, Volume= 0.392 af
 Outflow = 0.38 cfs @ 13.66 hrs, Volume= 0.228 af, Atten= 95%, Lag= 90.5 min
 Primary = 0.38 cfs @ 13.66 hrs, Volume= 0.228 af

Routing by Stor-Ind method, Time Span= 5.00-20.00 hrs, dt= 0.05 hrs
 Peak Elev= 716.99' @ 13.66 hrs Surf.Area= 11,973 sf Storage= 10,835 cf

Plug-Flow detention time= 226.0 min calculated for 0.228 af (58% of inflow)
 Center-of-Mass det. time= 157.8 min (957.1 - 799.3)

Volume	Invert	Avail.Storage	Storage Description
#1	716.00'	39,000 cf	Custom Stage Data (Prismatic) Listed below (Recalc)

Elevation (feet)	Surf.Area (sq-ft)	Inc.Store (cubic-feet)	Cum.Store (cubic-feet)
716.00	10,000	0	0
719.00	16,000	39,000	39,000

Device	Routing	Invert	Outlet Devices
#1	Primary	716.00'	12.0" Round Culvert L= 36.0' RCP, square edge headwall, Ke= 0.500 Inlet / Outlet Invert= 716.00' / 715.82' S= 0.0050 '/' Cc= 0.900 n= 0.013, Flow Area= 0.79 sf
#2	Device 1	716.00'	4.0" Vert. Orifice/Grate C= 0.600
#3	Device 1	717.00'	12.0" Horiz. Orifice/Grate C= 0.600 Limited to weir flow at low heads

Primary OutFlow Max=0.38 cfs @ 13.66 hrs HW=716.99' (Free Discharge)

- ↑ **1=Culvert** (Passes 0.38 cfs of 2.11 cfs potential flow)
- ↑ **2=Orifice/Grate** (Orifice Controls 0.38 cfs @ 4.36 fps)
- ↑ **3=Orifice/Grate** (Controls 0.00 cfs)

Pond MP: MIDDLE POND

Hydrograph

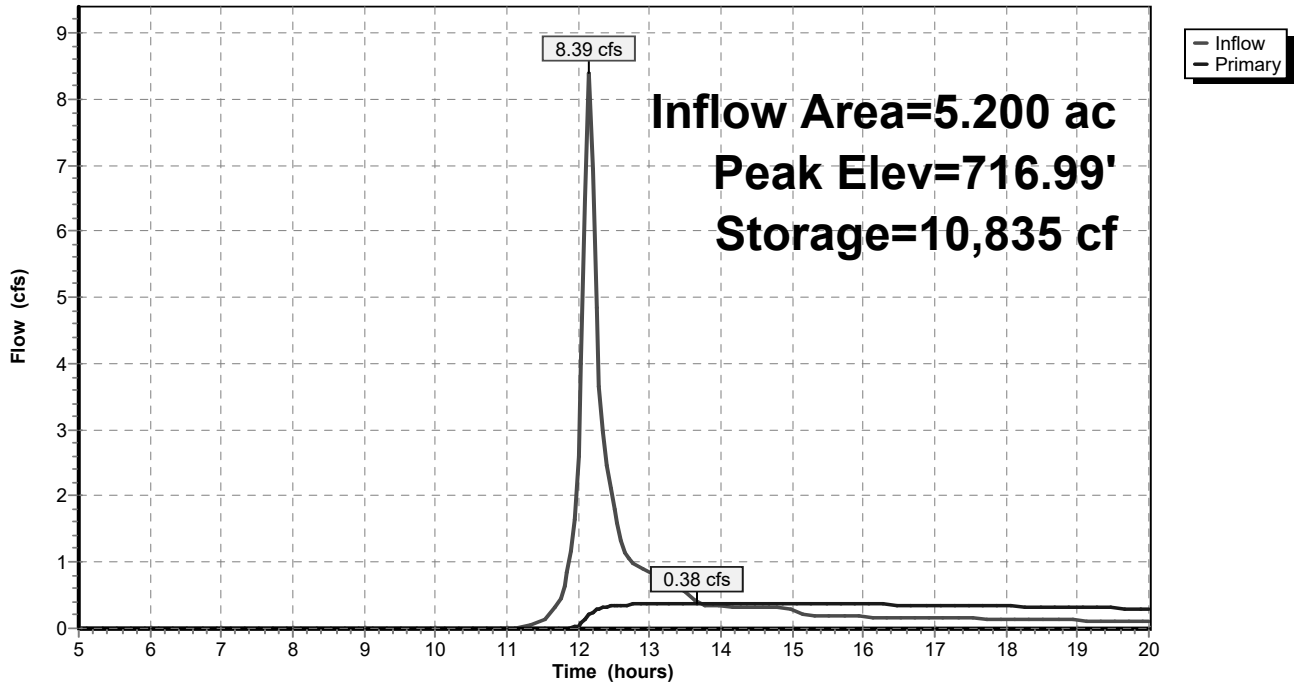

YORKVILLE

MSE 24-hr 3 2-YEAR Rainfall=2.67"

Prepared by {enter your company name here}

Printed 2/26/2021

HydroCAD® 10.00-22 s/n 07894 © 2018 HydroCAD Software Solutions LLC

Page 23

Summary for Pond NP: NORTH POND

Inflow Area = 21.400 ac, 9.35% Impervious, Inflow Depth > 0.76" for 2-YEAR event
 Inflow = 21.64 cfs @ 12.24 hrs, Volume= 1.362 af
 Outflow = 1.03 cfs @ 15.13 hrs, Volume= 0.633 af, Atten= 95%, Lag= 173.2 min
 Primary = 1.03 cfs @ 15.13 hrs, Volume= 0.633 af

Routing by Stor-Ind method, Time Span= 5.00-20.00 hrs, dt= 0.05 hrs
 Peak Elev= 717.44' @ 15.13 hrs Surf.Area= 32,556 sf Storage= 39,266 cf

Plug-Flow detention time= 231.5 min calculated for 0.631 af (46% of inflow)
 Center-of-Mass det. time= 157.1 min (966.9 - 809.8)

Volume	Invert	Avail.Storage	Storage Description
#1	716.00'	146,000 cf	Custom Stage Data (Prismatic) Listed below (Recalc)
Elevation (feet)	Surf.Area (sq-ft)	Inc.Store (cubic-feet)	Cum.Store (cubic-feet)
716.00	22,000	0	0
719.00	44,000	99,000	99,000
720.00	50,000	47,000	146,000

Device	Routing	Invert	Outlet Devices
#1	Primary	716.00'	24.0" Round Culvert L= 36.0' RCP, square edge headwall, Ke= 0.500 Inlet / Outlet Invert= 716.00' / 715.82' S= 0.0050 '/' Cc= 0.900 n= 0.013, Flow Area= 3.14 sf
#2	Device 1	716.00'	6.0" Vert. Orifice/Grate C= 0.600
#3	Device 1	717.50'	36.0" Vert. Orifice/Grate C= 0.600

Primary OutFlow Max=1.03 cfs @ 15.13 hrs HW=717.44' (Free Discharge)

- ↑ **1=Culvert** (Passes 1.03 cfs of 7.36 cfs potential flow)
- ↑ **2=Orifice/Grate** (Orifice Controls 1.03 cfs @ 5.25 fps)
- ↑ **3=Orifice/Grate** (Controls 0.00 cfs)

Pond NP: NORTH POND

Hydrograph

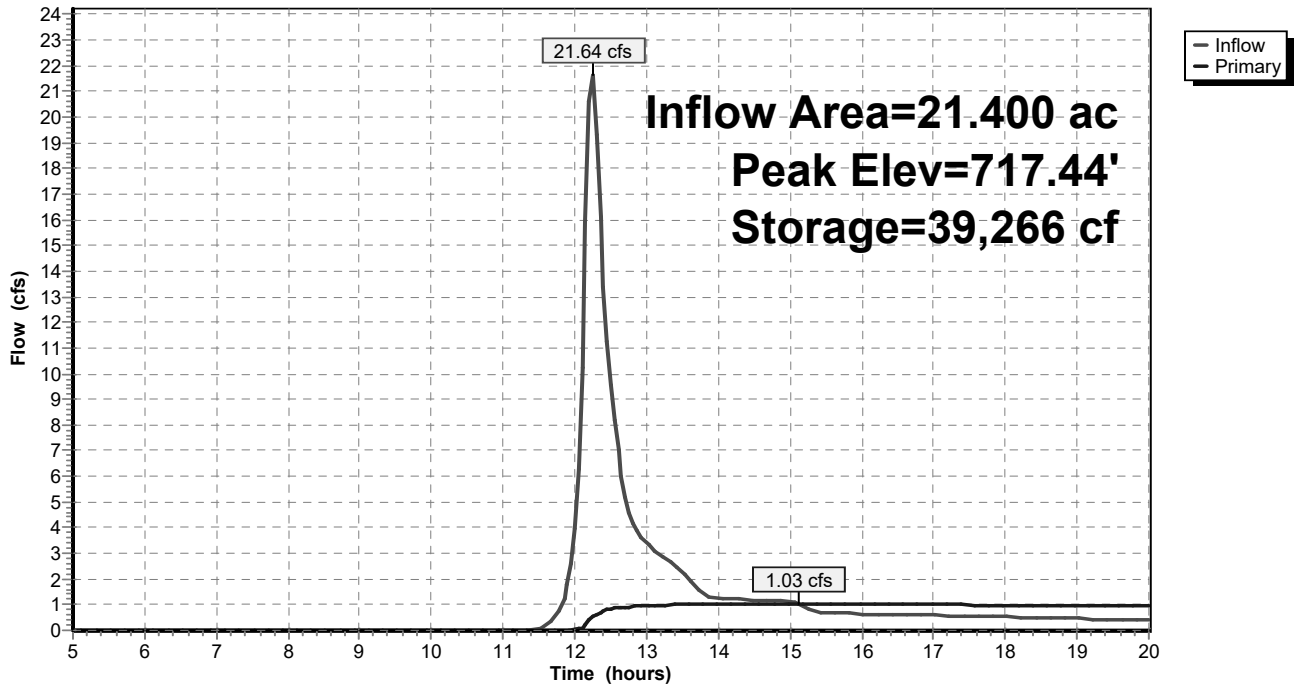

Summary for Pond SP: SOUTH POND

Inflow Area = 4.500 ac, 15.56% Impervious, Inflow Depth > 0.85" for 2-YEAR event
 Inflow = 6.74 cfs @ 12.16 hrs, Volume= 0.319 af
 Outflow = 0.34 cfs @ 13.63 hrs, Volume= 0.199 af, Atten= 95%, Lag= 88.6 min
 Primary = 0.34 cfs @ 13.63 hrs, Volume= 0.199 af

Routing by Stor-Ind method, Time Span= 5.00-20.00 hrs, dt= 0.05 hrs
 Peak Elev= 716.82' @ 13.63 hrs Surf.Area= 11,197 sf Storage= 8,625 cf

Plug-Flow detention time= 220.7 min calculated for 0.199 af (62% of inflow)
 Center-of-Mass det. time= 153.6 min (955.0 - 801.4)

Volume	Invert	Avail.Storage	Storage Description
#1	716.00'	37,050 cf	Custom Stage Data (Prismatic) Listed below (Recalc)
Elevation (feet)	Surf.Area (sq-ft)	Inc.Store (cubic-feet)	Cum.Store (cubic-feet)
716.00	9,800	0	0
719.00	14,900	37,050	37,050

Device	Routing	Invert	Outlet Devices
#1	Primary	716.00'	12.0" Round Culvert L= 36.0' RCP, square edge headwall, Ke= 0.500 Inlet / Outlet Invert= 716.00' / 715.82' S= 0.0050 '/' Cc= 0.900 n= 0.013, Flow Area= 0.79 sf
#2	Device 1	716.00'	4.0" Vert. Orifice/Grate C= 0.600
#3	Device 1	717.00'	12.0" Horiz. Orifice/Grate C= 0.600 Limited to weir flow at low heads

Primary OutFlow Max=0.34 cfs @ 13.63 hrs HW=716.82' (Free Discharge)

- ↑ **1=Culvert** (Passes 0.34 cfs of 1.61 cfs potential flow)
- ↑ **2=Orifice/Grate** (Orifice Controls 0.34 cfs @ 3.90 fps)
- ↑ **3=Orifice/Grate** (Controls 0.00 cfs)

Pond SP: SOUTH POND

Hydrograph

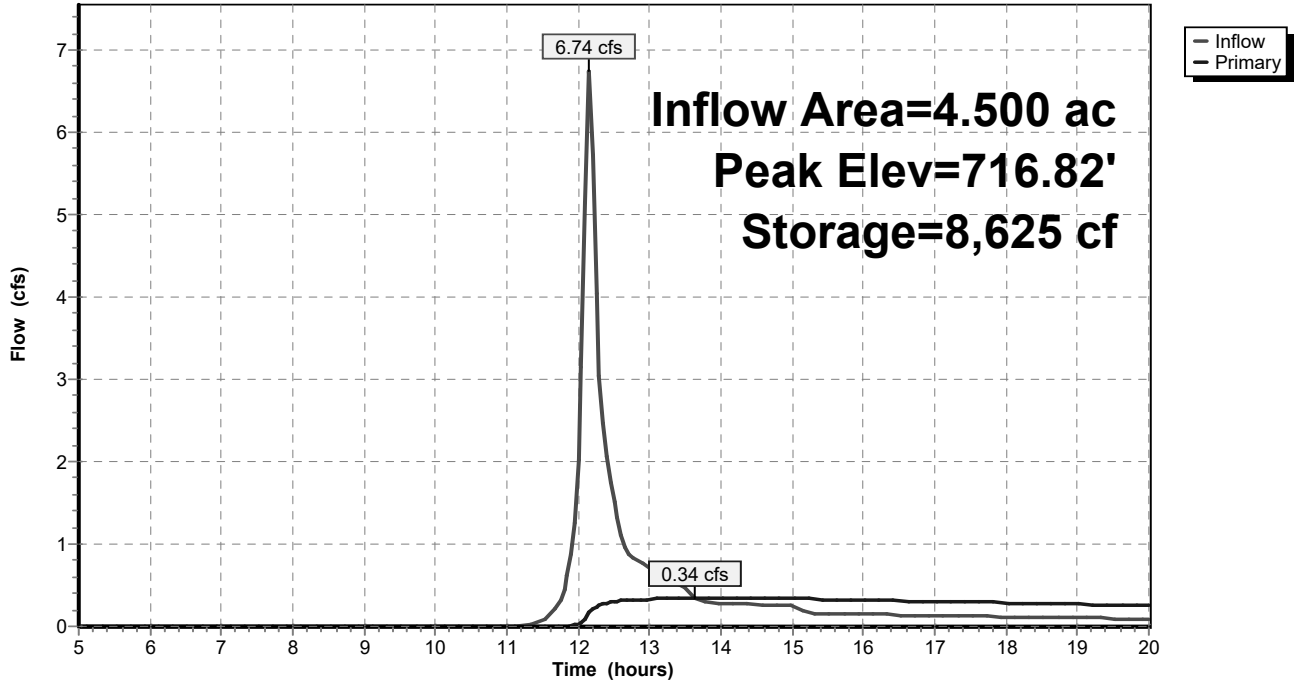

Summary for Link PSD: PROPOSED SITE DISCHARGE

Inflow Area = 32.900 ac, 12.16% Impervious, Inflow Depth > 0.43" for 2-YEAR event
Inflow = 3.42 cfs @ 12.15 hrs, Volume= 1.188 af
Primary = 3.42 cfs @ 12.15 hrs, Volume= 1.188 af, Atten= 0%, Lag= 0.0 min

Primary outflow = Inflow, Time Span= 5.00-20.00 hrs, dt= 0.05 hrs

Link PSD: PROPOSED SITE DISCHARGE

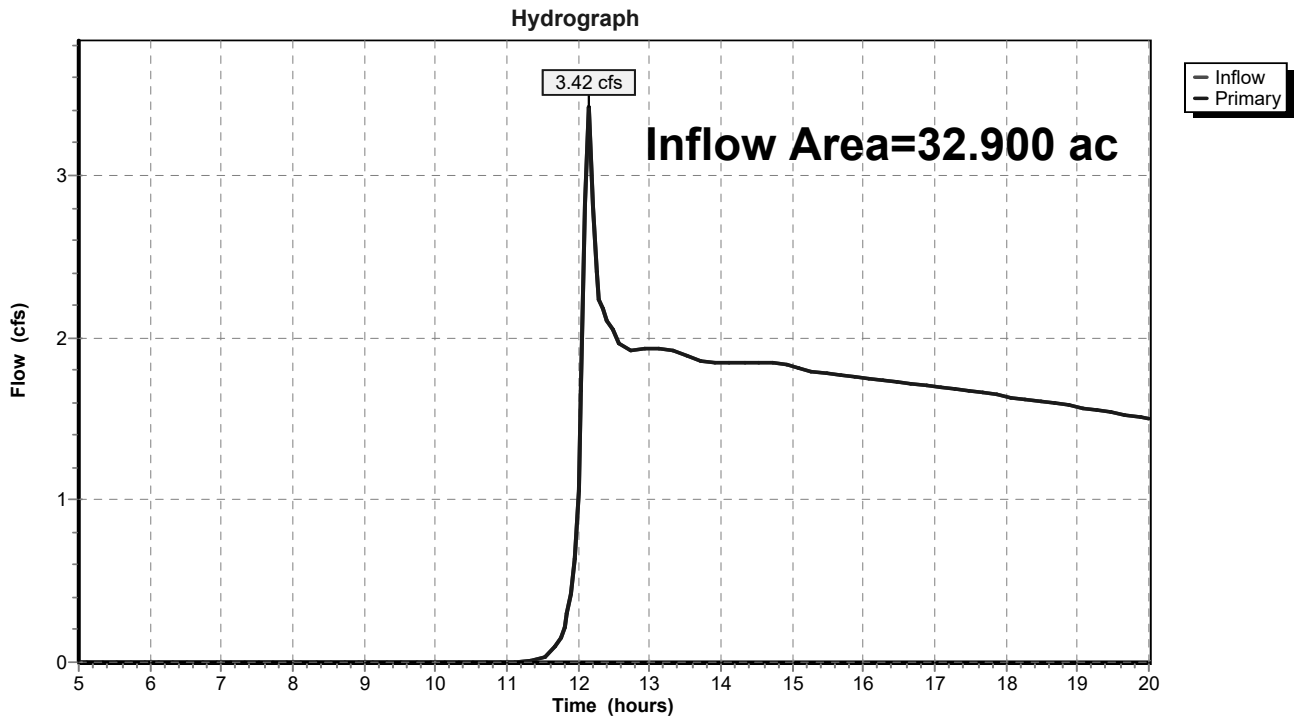

YORKVILLE

MSE 24-hr 3 10-YEAR Rainfall=3.77"

Prepared by {enter your company name here}

Printed 2/26/2021

HydroCAD® 10.00-22 s/n 07894 © 2018 HydroCAD Software Solutions LLC

Page 28

Time span=5.00-20.00 hrs, dt=0.05 hrs, 301 points
 Runoff by SCS TR-20 method, UH=SCS, Weighted-CN
 Reach routing by Stor-Ind+Trans method - Pond routing by Stor-Ind method

SubcatchmentAMP: AREA TO MIDDLE Runoff Area=5.200 ac 19.23% Impervious Runoff Depth>1.70"
 Flow Length=872' Tc=7.5 min CN=79 Runoff=15.85 cfs 0.736 af

SubcatchmentANP: AREA TO NORTH Runoff Area=18.400 ac 10.87% Impervious Runoff Depth>1.55"
 Flow Length=1,190' Tc=13.7 min CN=77 Runoff=39.83 cfs 2.382 af

SubcatchmentASP: AREA TO SOUTH Runoff Area=4.500 ac 15.56% Impervious Runoff Depth>1.63"
 Flow Length=803' Tc=7.6 min CN=78 Runoff=13.01 cfs 0.610 af

SubcatchmentOFF: OFFSITE AREA Runoff Area=3.000 ac 0.00% Impervious Runoff Depth>1.17"
 Flow Length=1,320' Slope=0.0200 '/' Tc=17.3 min CN=71 Runoff=4.27 cfs 0.292 af

SubcatchmentUND: UNDETAINED Runoff Area=1.800 ac 16.67% Impervious Runoff Depth>1.63"
 Tc=6.0 min CN=78 Runoff=5.52 cfs 0.244 af

Pond MP: MIDDLE POND Peak Elev=717.41' Storage=16,132 cf Inflow=15.85 cfs 0.736 af
 Outflow=2.90 cfs 0.526 af

Pond NP: NORTH POND Peak Elev=718.24' Storage=67,500 cf Inflow=43.83 cfs 2.674 af
 Outflow=5.26 cfs 1.657 af

Pond SP: SOUTH POND Peak Elev=717.29' Storage=14,024 cf Inflow=13.01 cfs 0.610 af
 Outflow=2.03 cfs 0.421 af

Link PSD: PROPOSED SITE DISCHARGE Inflow=9.94 cfs 2.848 af
 Primary=9.94 cfs 2.848 af

Total Runoff Area = 32.900 ac Runoff Volume = 4.264 af Average Runoff Depth = 1.56"
87.84% Pervious = 28.900 ac 12.16% Impervious = 4.000 ac

YORKVILLE

MSE 24-hr 3 10-YEAR Rainfall=3.77"

Prepared by {enter your company name here}

Printed 2/26/2021

HydroCAD® 10.00-22 s/n 07894 © 2018 HydroCAD Software Solutions LLC

Page 29

Summary for Subcatchment AMP: AREA TO MIDDLE POND

Runoff = 15.85 cfs @ 12.15 hrs, Volume= 0.736 af, Depth> 1.70"

Runoff by SCS TR-20 method, UH=SCS, Weighted-CN, Time Span= 5.00-20.00 hrs, dt= 0.05 hrs
MSE 24-hr 3 10-YEAR Rainfall=3.77"

Area (ac)	CN	Description
* 0.300	98	ROOF
* 0.500	98	PAVEMENT
* 0.200	99	WATER SURFACE
* 4.200	74	GRASS
5.200	79	Weighted Average
4.200		80.77% Pervious Area
1.000		19.23% Impervious Area

Tc (min)	Length (feet)	Slope (ft/ft)	Velocity (ft/sec)	Capacity (cfs)	Description
4.9	60	0.0500	0.20		Sheet Flow, SHEET Grass: Short n= 0.150 P2= 2.67"
2.6	812	0.0150	5.16	54.22	Trap/Vee/Rect Channel Flow, Ditch Bot.W=1.00' D=1.50' Z= 4.0 '/' Top.W=13.00' n= 0.030 Earth, grassed & winding
7.5	872	Total			

Subcatchment AMP: AREA TO MIDDLE POND

Hydrograph

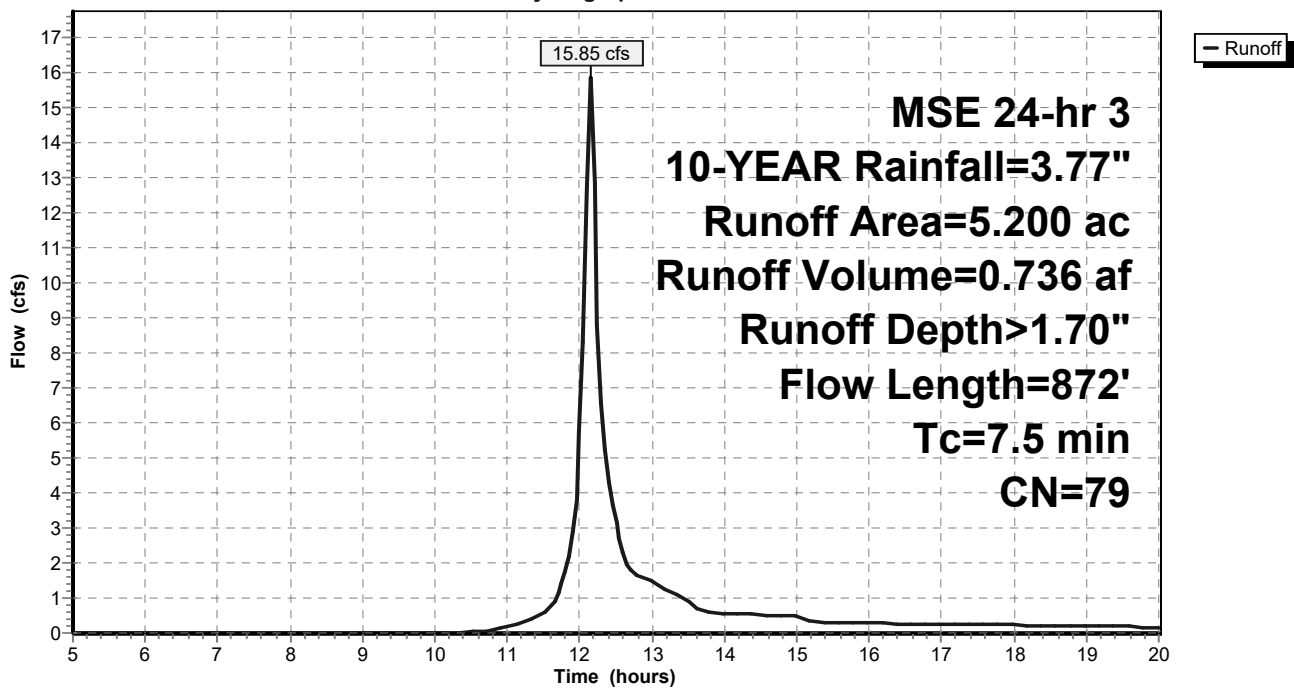

Summary for Subcatchment ANP: AREA TO NORTH POND

Runoff = 39.83 cfs @ 12.23 hrs, Volume= 2.382 af, Depth> 1.55"

Runoff by SCS TR-20 method, UH=SCS, Weighted-CN, Time Span= 5.00-20.00 hrs, dt= 0.05 hrs
MSE 24-hr 3 10-YEAR Rainfall=3.77"

Area (ac)	CN	Description
* 0.800	98	ROOF
* 0.700	98	PAVEMENT
* 0.500	99	WATER SURFACE
* 16.400	74	GRASS
18.400	77	Weighted Average
16.400		89.13% Pervious Area
2.000		10.87% Impervious Area

Tc (min)	Length (feet)	Slope (ft/ft)	Velocity (ft/sec)	Capacity (cfs)	Description
9.3	220	0.0220	0.39		Sheet Flow, Sheet Cultivated: Residue<=20% n= 0.060 P2= 2.67"
2.0	235	0.0170	1.96		Shallow Concentrated Flow, Shallow Grassed Waterway Kv= 15.0 fps
2.4	735	0.0150	5.16	54.22	Trap/Vee/Rect Channel Flow, Swale Bot.W=1.00' D=1.50' Z= 4.0 '/' Top.W=13.00' n= 0.030 Earth, grassed & winding
13.7	1,190	Total			

Subcatchment ANP: AREA TO NORTH POND

Hydrograph

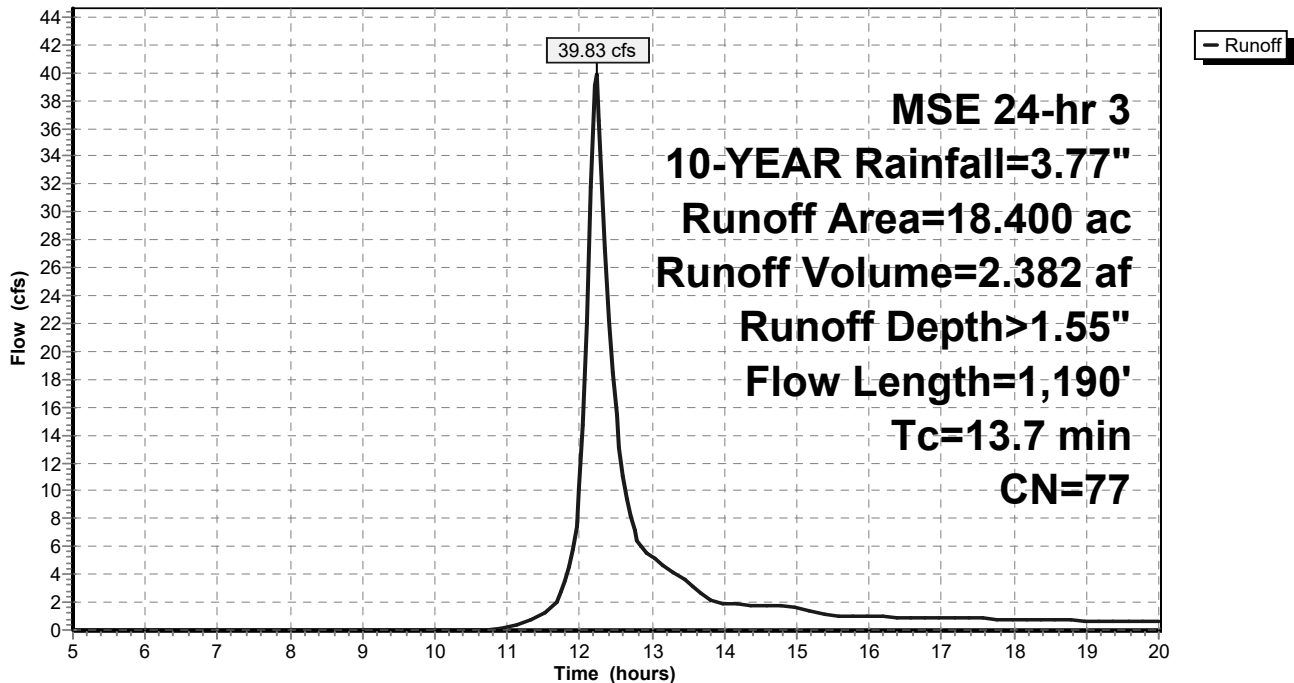

YORKVILLE

MSE 24-hr 3 10-YEAR Rainfall=3.77"

Prepared by {enter your company name here}

Printed 2/26/2021

HydroCAD® 10.00-22 s/n 07894 © 2018 HydroCAD Software Solutions LLC

Page 31

Summary for Subcatchment ASP: AREA TO SOUTH POND

Runoff = 13.01 cfs @ 12.15 hrs, Volume= 0.610 af, Depth> 1.63"

Runoff by SCS TR-20 method, UH=SCS, Weighted-CN, Time Span= 5.00-20.00 hrs, dt= 0.05 hrs
MSE 24-hr 3 10-YEAR Rainfall=3.77"

Area (ac)	CN	Description
* 0.300	98	ROOF
* 0.200	98	PAVEMENT
* 0.200	99	WATER SURFACE
* 3.800	74	GRASS
4.500	78	Weighted Average
3.800		84.44% Pervious Area
0.700		15.56% Impervious Area

Tc (min)	Length (feet)	Slope (ft/ft)	Velocity (ft/sec)	Capacity (cfs)	Description
5.2	64	0.0500	0.21		Sheet Flow, Sheet Grass: Short n= 0.150 P2= 2.67"
2.4	739	0.0150	5.16	54.22	Trap/Vee/Rect Channel Flow, Ditch Bot.W=1.00' D=1.50' Z= 4.0 '/' Top.W=13.00' n= 0.030 Earth, grassed & winding
7.6	803	Total			

Subcatchment ASP: AREA TO SOUTH POND

Hydrograph

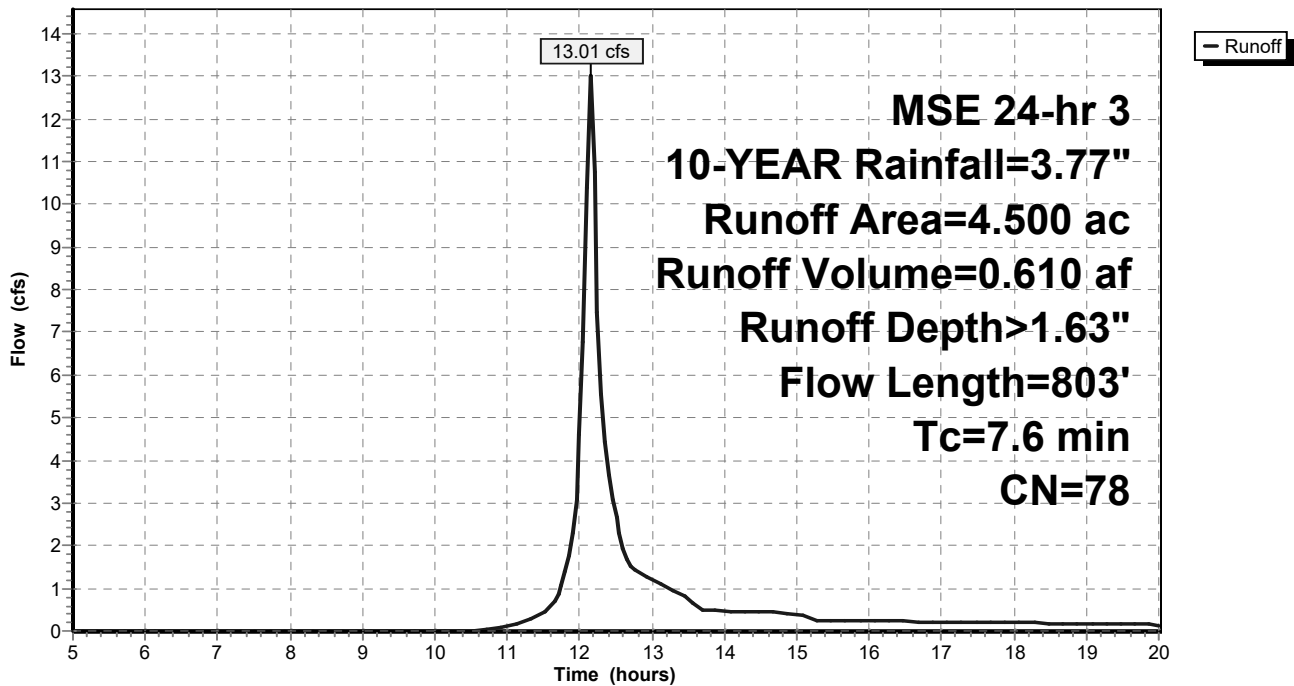

Summary for Subcatchment OFF: OFFSITE AREA

Runoff = 4.27 cfs @ 12.28 hrs, Volume= 0.292 af, Depth> 1.17"

Runoff by SCS TR-20 method, UH=SCS, Weighted-CN, Time Span= 5.00-20.00 hrs, dt= 0.05 hrs
MSE 24-hr 3 10-YEAR Rainfall=3.77"

Area (ac)	CN	Description
* 3.000	71	AG LANDS
3.000		100.00% Pervious Area

Tc (min)	Length (feet)	Slope (ft/ft)	Velocity (ft/sec)	Capacity (cfs)	Description
17.3	1,320	0.0200	1.27		Shallow Concentrated Flow, SHALLOW CONCENTRATED Cultivated Straight Rows Kv= 9.0 fps

Subcatchment OFF: OFFSITE AREA

Hydrograph

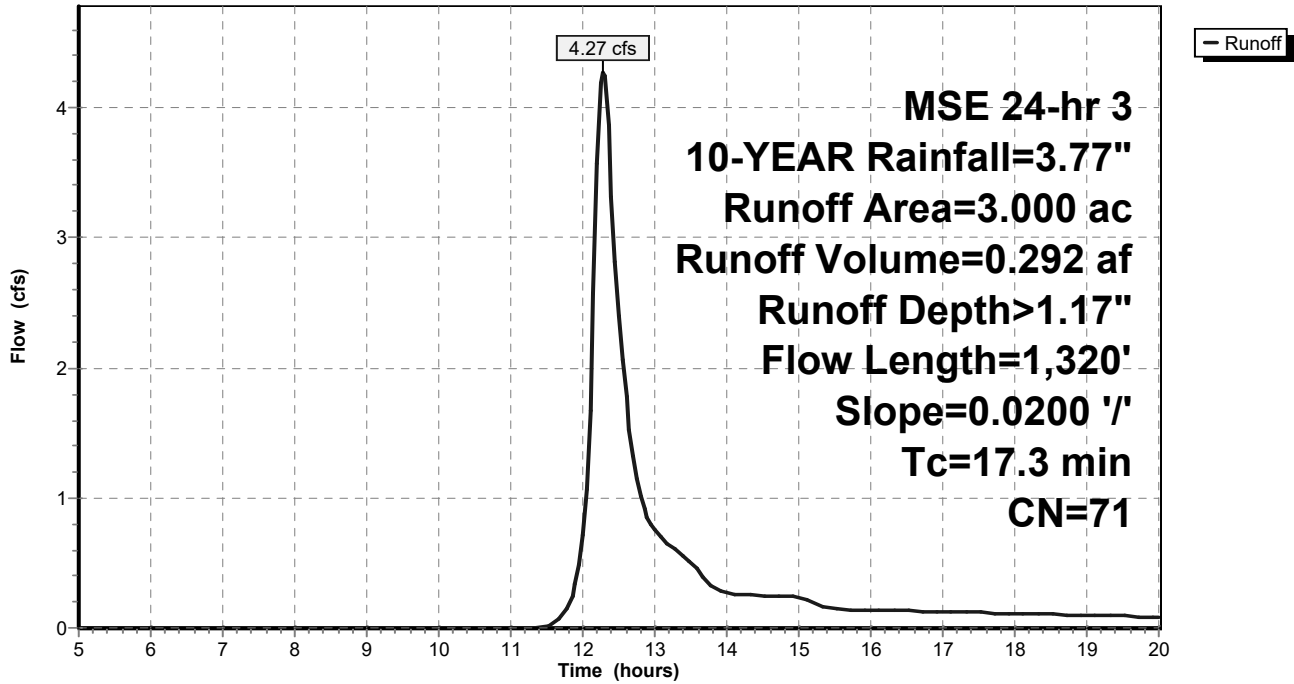

YORKVILLE

MSE 24-hr 3 10-YEAR Rainfall=3.77"

Prepared by {enter your company name here}

Printed 2/26/2021

HydroCAD® 10.00-22 s/n 07894 © 2018 HydroCAD Software Solutions LLC

Page 33

Summary for Subcatchment UND: UNDETAINED

Runoff = 5.52 cfs @ 12.14 hrs, Volume= 0.244 af, Depth> 1.63"

Runoff by SCS TR-20 method, UH=SCS, Weighted-CN, Time Span= 5.00-20.00 hrs, dt= 0.05 hrs
 MSE 24-hr 3 10-YEAR Rainfall=3.77"

Area (ac)	CN	Description
* 0.100	98	ROOF
* 0.200	98	PAVEMENT
* 1.500	74	GRASS
1.800	78	Weighted Average
1.500		83.33% Pervious Area
0.300		16.67% Impervious Area

Tc (min)	Length (feet)	Slope (ft/ft)	Velocity (ft/sec)	Capacity (cfs)	Description
6.0					Direct Entry, MIN PER TR-55

Subcatchment UND: UNDETAINED

Hydrograph

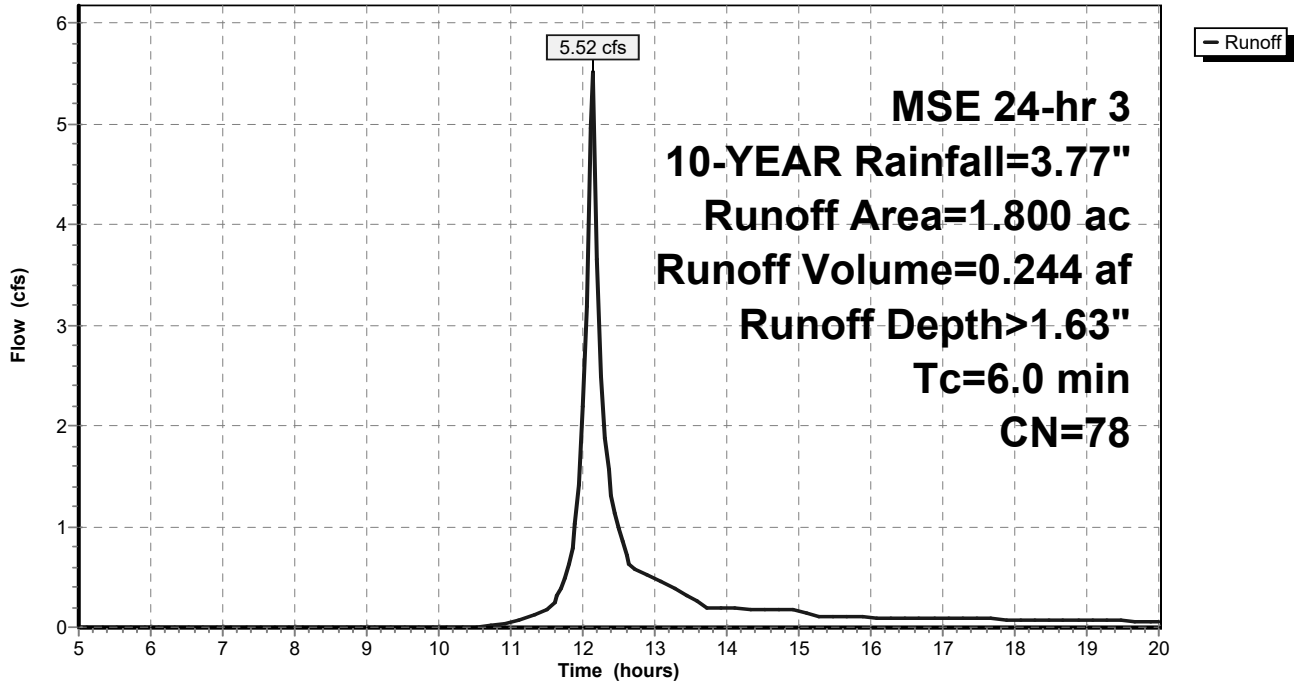

Summary for Pond MP: MIDDLE POND

Inflow Area = 5.200 ac, 19.23% Impervious, Inflow Depth > 1.70" for 10-YEAR event
 Inflow = 15.85 cfs @ 12.15 hrs, Volume= 0.736 af
 Outflow = 2.90 cfs @ 12.53 hrs, Volume= 0.526 af, Atten= 82%, Lag= 22.7 min
 Primary = 2.90 cfs @ 12.53 hrs, Volume= 0.526 af

Routing by Stor-Ind method, Time Span= 5.00-20.00 hrs, dt= 0.05 hrs
 Peak Elev= 717.41' @ 12.53 hrs Surf.Area= 12,827 sf Storage= 16,132 cf

Plug-Flow detention time= 135.8 min calculated for 0.524 af (71% of inflow)
 Center-of-Mass det. time= 80.7 min (869.5 - 788.8)

Volume	Invert	Avail.Storage	Storage Description
#1	716.00'	39,000 cf	Custom Stage Data (Prismatic) Listed below (Recalc)

Elevation (feet)	Surf.Area (sq-ft)	Inc.Store (cubic-feet)	Cum.Store (cubic-feet)
716.00	10,000	0	0
719.00	16,000	39,000	39,000

Device	Routing	Invert	Outlet Devices
#1	Primary	716.00'	12.0" Round Culvert L= 36.0' RCP, square edge headwall, Ke= 0.500 Inlet / Outlet Invert= 716.00' / 715.82' S= 0.0050 '/' Cc= 0.900 n= 0.013, Flow Area= 0.79 sf
#2	Device 1	716.00'	4.0" Vert. Orifice/Grate C= 0.600
#3	Device 1	717.00'	12.0" Horiz. Orifice/Grate C= 0.600 Limited to weir flow at low heads

Primary OutFlow Max=2.90 cfs @ 12.53 hrs HW=717.41' (Free Discharge)

- ↑ **1=Culvert** (Passes 2.90 cfs of 2.99 cfs potential flow)
- ↑ **2=Orifice/Grate** (Orifice Controls 0.47 cfs @ 5.37 fps)
- ↑ **3=Orifice/Grate** (Orifice Controls 2.43 cfs @ 3.09 fps)

Pond MP: MIDDLE POND

Hydrograph

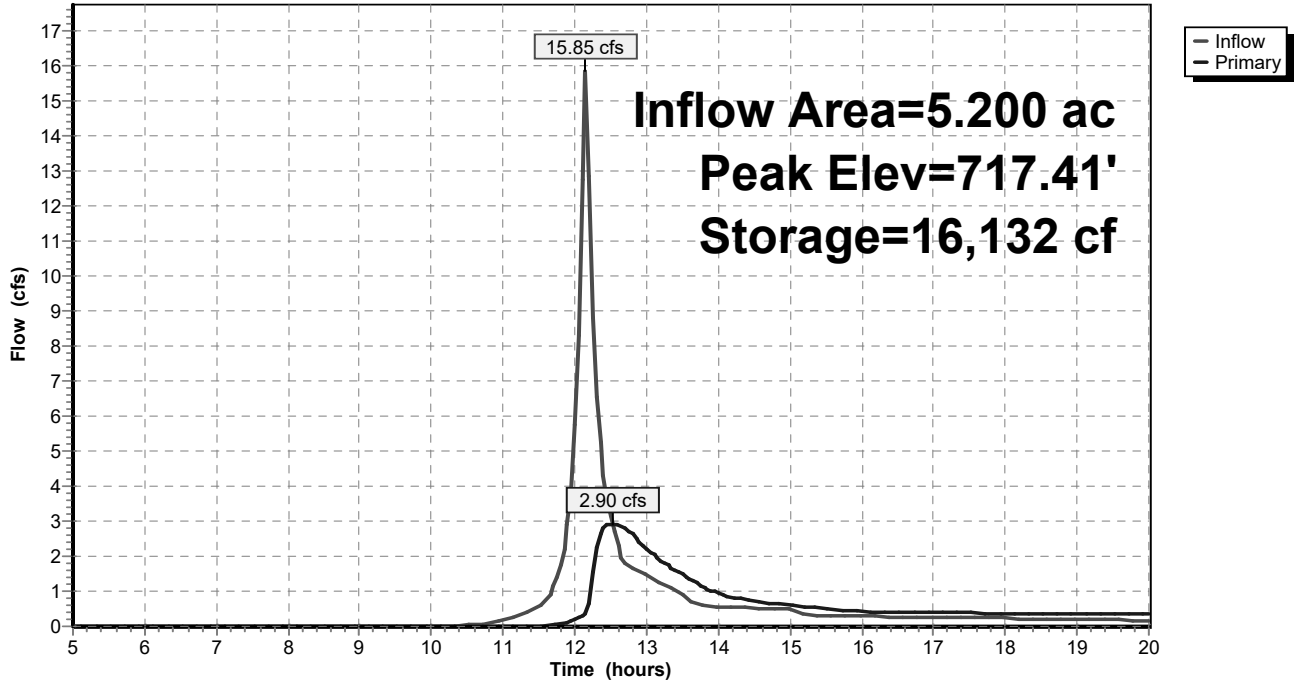

Summary for Pond NP: NORTH POND

Inflow Area = 21.400 ac, 9.35% Impervious, Inflow Depth > 1.50" for 10-YEAR event
 Inflow = 43.83 cfs @ 12.23 hrs, Volume= 2.674 af
 Outflow = 5.26 cfs @ 13.17 hrs, Volume= 1.657 af, Atten= 88%, Lag= 56.5 min
 Primary = 5.26 cfs @ 13.17 hrs, Volume= 1.657 af

Routing by Stor-Ind method, Time Span= 5.00-20.00 hrs, dt= 0.05 hrs
 Peak Elev= 718.24' @ 13.17 hrs Surf.Area= 38,393 sf Storage= 67,500 cf

Plug-Flow detention time= 171.3 min calculated for 1.657 af (62% of inflow)
 Center-of-Mass det. time= 108.4 min (906.9 - 798.5)

Volume	Invert	Avail.Storage	Storage Description
#1	716.00'	146,000 cf	Custom Stage Data (Prismatic) Listed below (Recalc)
Elevation (feet)	Surf.Area (sq-ft)	Inc.Store (cubic-feet)	Cum.Store (cubic-feet)
716.00	22,000	0	0
719.00	44,000	99,000	99,000
720.00	50,000	47,000	146,000

Device	Routing	Invert	Outlet Devices
#1	Primary	716.00'	24.0" Round Culvert L= 36.0' RCP, square edge headwall, Ke= 0.500 Inlet / Outlet Invert= 716.00' / 715.82' S= 0.0050 '/' Cc= 0.900 n= 0.013, Flow Area= 3.14 sf
#2	Device 1	716.00'	6.0" Vert. Orifice/Grate C= 0.600
#3	Device 1	717.50'	36.0" Vert. Orifice/Grate C= 0.600

Primary OutFlow Max=5.25 cfs @ 13.17 hrs HW=718.24' (Free Discharge)

- ↑ **1=Culvert** (Passes 5.25 cfs of 14.28 cfs potential flow)
- ↑ **2=Orifice/Grate** (Orifice Controls 1.33 cfs @ 6.78 fps)
- ↑ **3=Orifice/Grate** (Orifice Controls 3.92 cfs @ 2.92 fps)

Pond NP: NORTH POND

Hydrograph

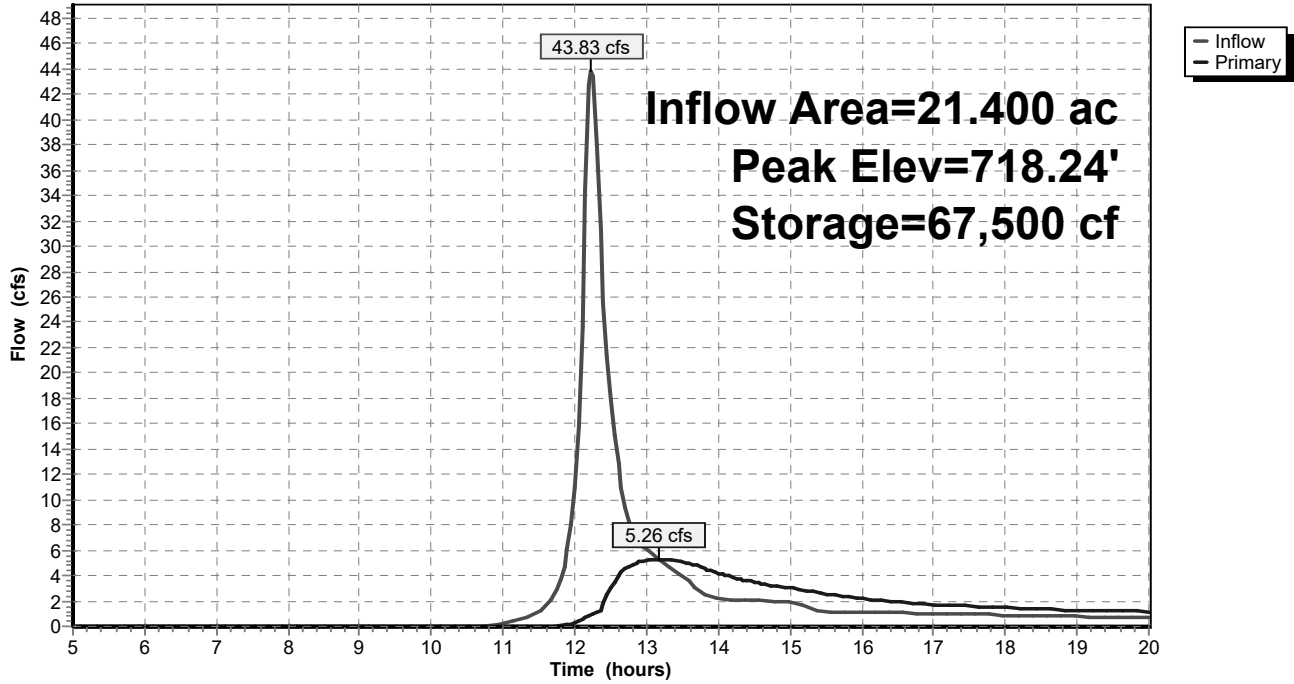

Summary for Pond SP: SOUTH POND

Inflow Area = 4.500 ac, 15.56% Impervious, Inflow Depth > 1.63" for 10-YEAR event
 Inflow = 13.01 cfs @ 12.15 hrs, Volume= 0.610 af
 Outflow = 2.03 cfs @ 12.59 hrs, Volume= 0.421 af, Atten= 84%, Lag= 26.4 min
 Primary = 2.03 cfs @ 12.59 hrs, Volume= 0.421 af

Routing by Stor-Ind method, Time Span= 5.00-20.00 hrs, dt= 0.05 hrs
 Peak Elev= 717.29' @ 12.59 hrs Surf.Area= 11,988 sf Storage= 14,024 cf

Plug-Flow detention time= 154.8 min calculated for 0.420 af (69% of inflow)
 Center-of-Mass det. time= 97.4 min (887.9 - 790.6)

Volume	Invert	Avail.Storage	Storage Description
#1	716.00'	37,050 cf	Custom Stage Data (Prismatic) Listed below (Recalc)

Elevation (feet)	Surf.Area (sq-ft)	Inc.Store (cubic-feet)	Cum.Store (cubic-feet)
716.00	9,800	0	0
719.00	14,900	37,050	37,050

Device	Routing	Invert	Outlet Devices
#1	Primary	716.00'	12.0" Round Culvert L= 36.0' RCP, square edge headwall, Ke= 0.500 Inlet / Outlet Invert= 716.00' / 715.82' S= 0.0050 '/' Cc= 0.900 n= 0.013, Flow Area= 0.79 sf
#2	Device 1	716.00'	4.0" Vert. Orifice/Grate C= 0.600
#3	Device 1	717.00'	12.0" Horiz. Orifice/Grate C= 0.600 Limited to weir flow at low heads

Primary OutFlow Max=2.02 cfs @ 12.59 hrs HW=717.29' (Free Discharge)

- ↑ **1=Culvert** (Passes 2.02 cfs of 2.81 cfs potential flow)
- ↑ **2=Orifice/Grate** (Orifice Controls 0.44 cfs @ 5.10 fps)
- ↑ **3=Orifice/Grate** (Weir Controls 1.58 cfs @ 1.75 fps)

Pond SP: SOUTH POND

Hydrograph

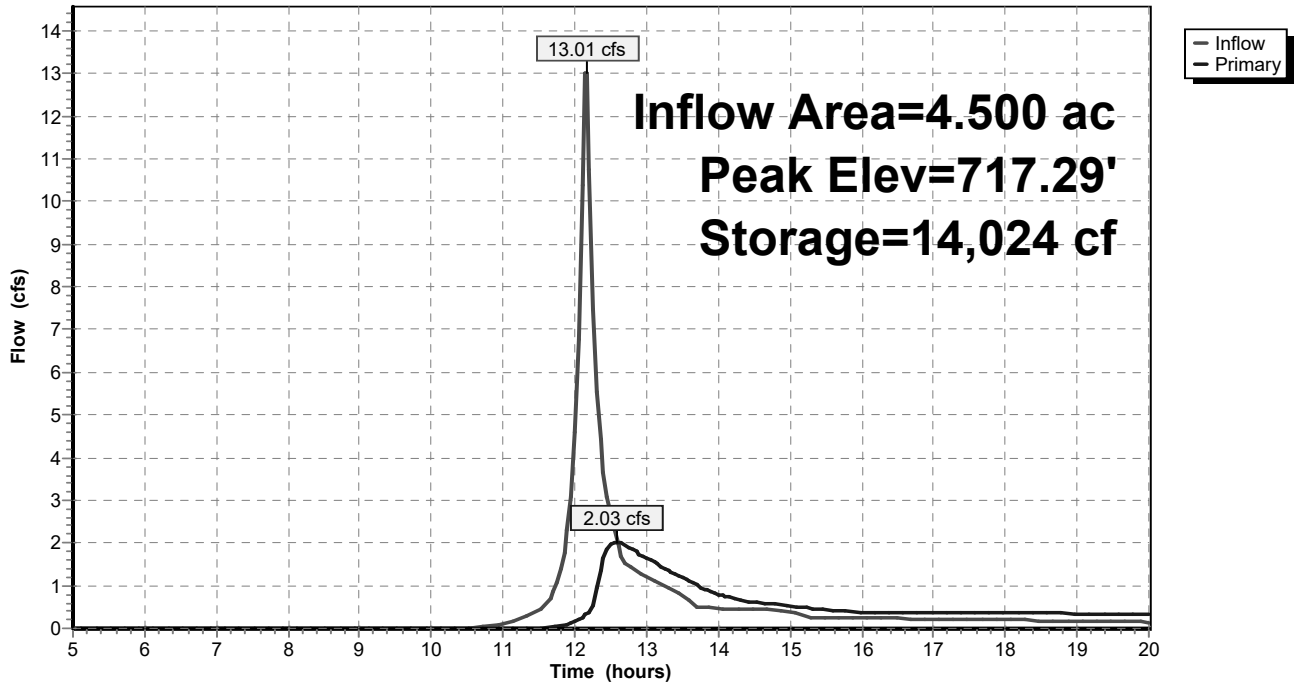

Summary for Link PSD: PROPOSED SITE DISCHARGE

Inflow Area = 32.900 ac, 12.16% Impervious, Inflow Depth > 1.04" for 10-YEAR event
Inflow = 9.94 cfs @ 12.75 hrs, Volume= 2.848 af
Primary = 9.94 cfs @ 12.75 hrs, Volume= 2.848 af, Atten= 0%, Lag= 0.0 min

Primary outflow = Inflow, Time Span= 5.00-20.00 hrs, dt= 0.05 hrs

Link PSD: PROPOSED SITE DISCHARGE

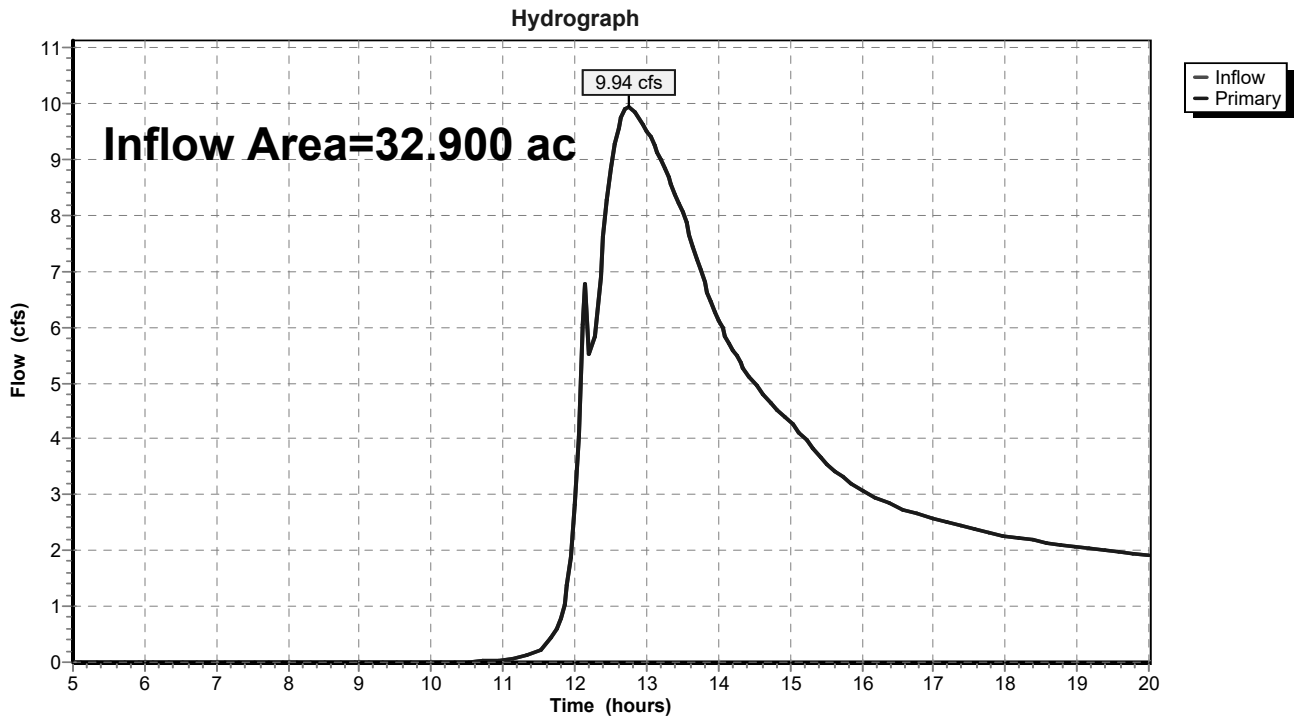

YORKVILLE

MSE 24-hr 3 100-YEAR Rainfall=5.92"

Prepared by {enter your company name here}

Printed 2/26/2021

HydroCAD® 10.00-22 s/n 07894 © 2018 HydroCAD Software Solutions LLC

Page 41

Time span=5.00-20.00 hrs, dt=0.05 hrs, 301 points
 Runoff by SCS TR-20 method, UH=SCS, Weighted-CN
 Reach routing by Stor-Ind+Trans method - Pond routing by Stor-Ind method

SubcatchmentAMP: AREA TO MIDDLE Runoff Area=5.200 ac 19.23% Impervious Runoff Depth>3.47"
 Flow Length=872' Tc=7.5 min CN=79 Runoff=31.73 cfs 1.502 af

SubcatchmentANP: AREA TO NORTH Runoff Area=18.400 ac 10.87% Impervious Runoff Depth>3.26"
 Flow Length=1,190' Tc=13.7 min CN=77 Runoff=83.92 cfs 5.006 af

SubcatchmentASP: AREA TO SOUTH Runoff Area=4.500 ac 15.56% Impervious Runoff Depth>3.37"
 Flow Length=803' Tc=7.6 min CN=78 Runoff=26.50 cfs 1.263 af

SubcatchmentOFF: OFFSITE AREA Runoff Area=3.000 ac 0.00% Impervious Runoff Depth>2.70"
 Flow Length=1,320' Slope=0.0200 '/' Tc=17.3 min CN=71 Runoff=10.21 cfs 0.675 af

SubcatchmentUND: UNDETAINED Runoff Area=1.800 ac 16.67% Impervious Runoff Depth>3.37"
 Tc=6.0 min CN=78 Runoff=11.18 cfs 0.505 af

Pond MP: MIDDLE POND Peak Elev=718.66' Storage=33,640 cf Inflow=31.73 cfs 1.502 af
 Outflow=5.27 cfs 1.251 af

Pond NP: NORTH POND Peak Elev=719.53' Storage=123,046 cf Inflow=93.49 cfs 5.681 af
 Outflow=23.60 cfs 4.531 af

Pond SP: SOUTH POND Peak Elev=718.35' Storage=27,756 cf Inflow=26.50 cfs 1.263 af
 Outflow=4.81 cfs 1.029 af

Link PSD: PROPOSED SITE DISCHARGE Inflow=35.18 cfs 7.317 af
 Primary=35.18 cfs 7.317 af

Total Runoff Area = 32.900 ac Runoff Volume = 8.951 af Average Runoff Depth = 3.26"
87.84% Pervious = 28.900 ac 12.16% Impervious = 4.000 ac

YORKVILLE

MSE 24-hr 3 100-YEAR Rainfall=5.92"

Prepared by {enter your company name here}

Printed 2/26/2021

HydroCAD® 10.00-22 s/n 07894 © 2018 HydroCAD Software Solutions LLC

Page 42

Summary for Subcatchment AMP: AREA TO MIDDLE POND

Runoff = 31.73 cfs @ 12.15 hrs, Volume= 1.502 af, Depth> 3.47"

Runoff by SCS TR-20 method, UH=SCS, Weighted-CN, Time Span= 5.00-20.00 hrs, dt= 0.05 hrs
MSE 24-hr 3 100-YEAR Rainfall=5.92"

Area (ac)	CN	Description
* 0.300	98	ROOF
* 0.500	98	PAVEMENT
* 0.200	99	WATER SURFACE
* 4.200	74	GRASS
5.200	79	Weighted Average
4.200		80.77% Pervious Area
1.000		19.23% Impervious Area

Tc (min)	Length (feet)	Slope (ft/ft)	Velocity (ft/sec)	Capacity (cfs)	Description
4.9	60	0.0500	0.20		Sheet Flow, SHEET Grass: Short n= 0.150 P2= 2.67"
2.6	812	0.0150	5.16	54.22	Trap/Vee/Rect Channel Flow, Ditch Bot.W=1.00' D=1.50' Z= 4.0 '/' Top.W=13.00' n= 0.030 Earth, grassed & winding
7.5	872	Total			

Subcatchment AMP: AREA TO MIDDLE POND

Hydrograph

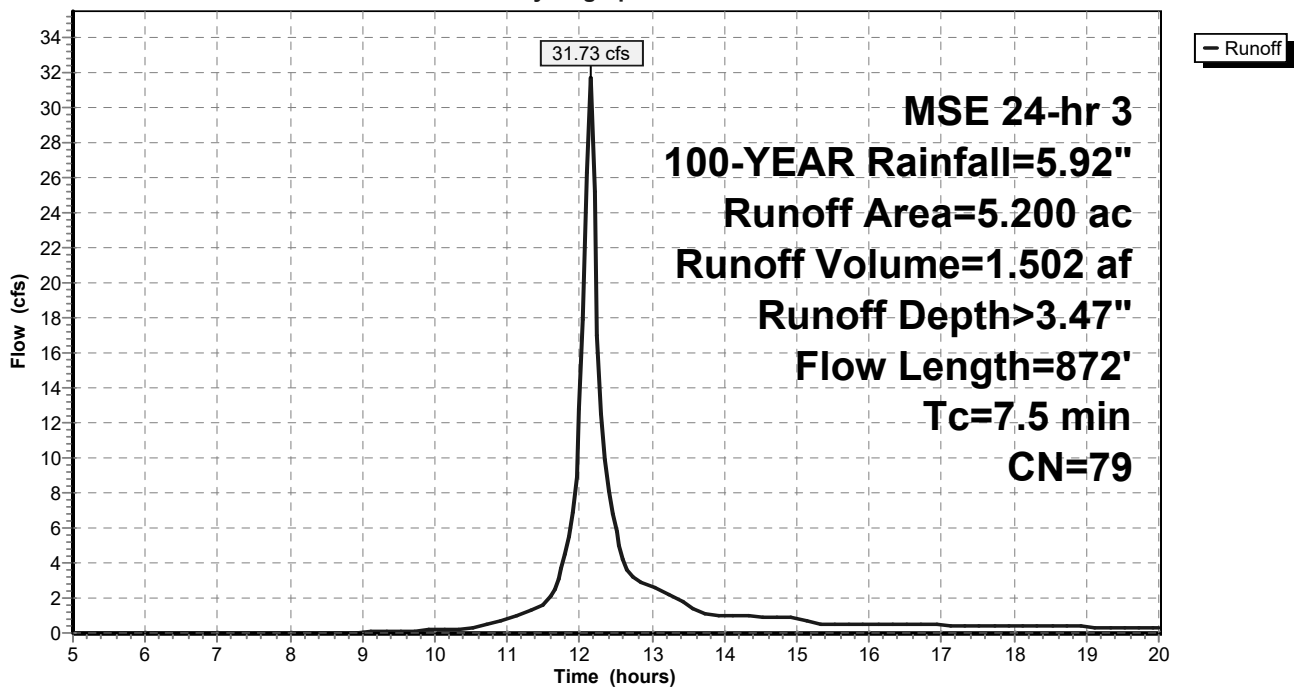

YORKVILLE

MSE 24-hr 3 100-YEAR Rainfall=5.92"

Prepared by {enter your company name here}

Printed 2/26/2021

HydroCAD® 10.00-22 s/n 07894 © 2018 HydroCAD Software Solutions LLC

Page 43

Summary for Subcatchment ANP: AREA TO NORTH POND

Runoff = 83.92 cfs @ 12.22 hrs, Volume= 5.006 af, Depth> 3.26"

Runoff by SCS TR-20 method, UH=SCS, Weighted-CN, Time Span= 5.00-20.00 hrs, dt= 0.05 hrs
MSE 24-hr 3 100-YEAR Rainfall=5.92"

Area (ac)	CN	Description
* 0.800	98	ROOF
* 0.700	98	PAVEMENT
* 0.500	99	WATER SURFACE
* 16.400	74	GRASS
18.400	77	Weighted Average
16.400		89.13% Pervious Area
2.000		10.87% Impervious Area

Tc (min)	Length (feet)	Slope (ft/ft)	Velocity (ft/sec)	Capacity (cfs)	Description
9.3	220	0.0220	0.39		Sheet Flow, Sheet Cultivated: Residue<=20% n= 0.060 P2= 2.67"
2.0	235	0.0170	1.96		Shallow Concentrated Flow, Shallow Grassed Waterway Kv= 15.0 fps
2.4	735	0.0150	5.16	54.22	Trap/Vee/Rect Channel Flow, Swale Bot.W=1.00' D=1.50' Z= 4.0 '/' Top.W=13.00' n= 0.030 Earth, grassed & winding
13.7	1,190	Total			

Subcatchment ANP: AREA TO NORTH POND

Hydrograph

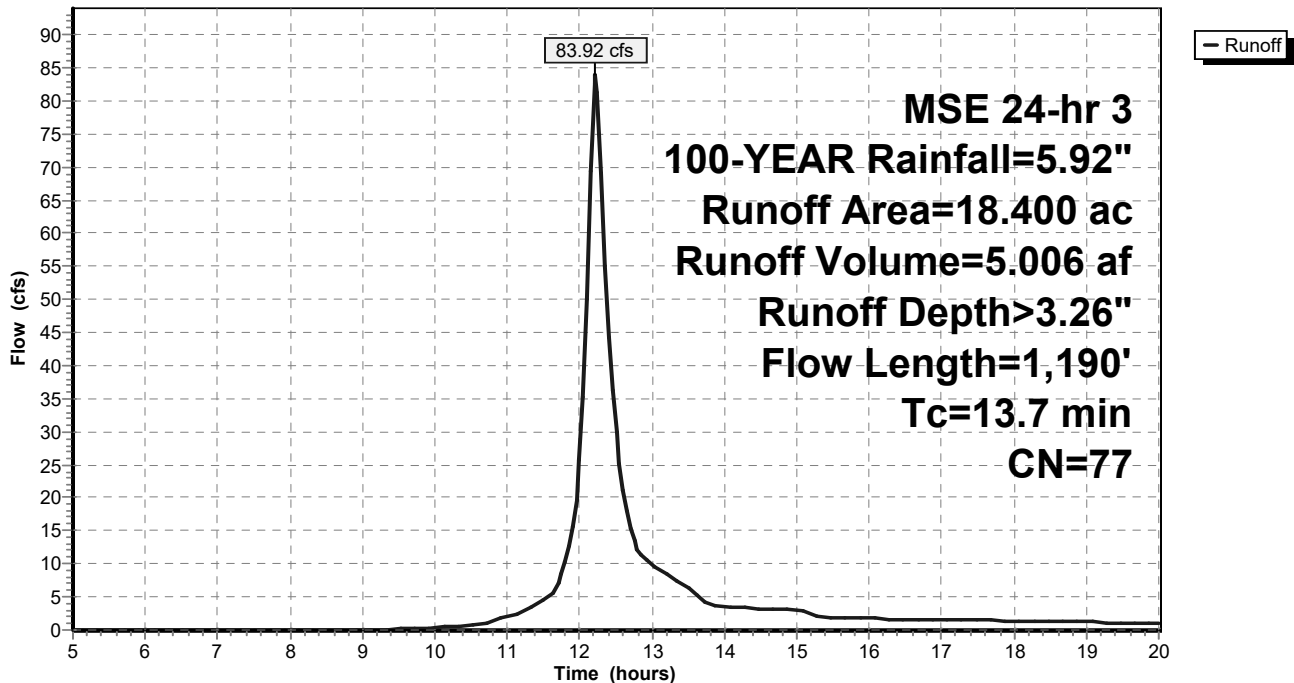

YORKVILLE

MSE 24-hr 3 100-YEAR Rainfall=5.92"

Prepared by {enter your company name here}

Printed 2/26/2021

HydroCAD® 10.00-22 s/n 07894 © 2018 HydroCAD Software Solutions LLC

Page 44

Summary for Subcatchment ASP: AREA TO SOUTH POND

Runoff = 26.50 cfs @ 12.15 hrs, Volume= 1.263 af, Depth> 3.37"

Runoff by SCS TR-20 method, UH=SCS, Weighted-CN, Time Span= 5.00-20.00 hrs, dt= 0.05 hrs
MSE 24-hr 3 100-YEAR Rainfall=5.92"

Area (ac)	CN	Description
* 0.300	98	ROOF
* 0.200	98	PAVEMENT
* 0.200	99	WATER SURFACE
* 3.800	74	GRASS
4.500	78	Weighted Average
3.800		84.44% Pervious Area
0.700		15.56% Impervious Area

Tc (min)	Length (feet)	Slope (ft/ft)	Velocity (ft/sec)	Capacity (cfs)	Description
5.2	64	0.0500	0.21		Sheet Flow, Sheet Grass: Short n= 0.150 P2= 2.67"
2.4	739	0.0150	5.16	54.22	Trap/Vee/Rect Channel Flow, Ditch Bot.W=1.00' D=1.50' Z= 4.0 '/' Top.W=13.00' n= 0.030 Earth, grassed & winding
7.6	803	Total			

Subcatchment ASP: AREA TO SOUTH POND

Hydrograph

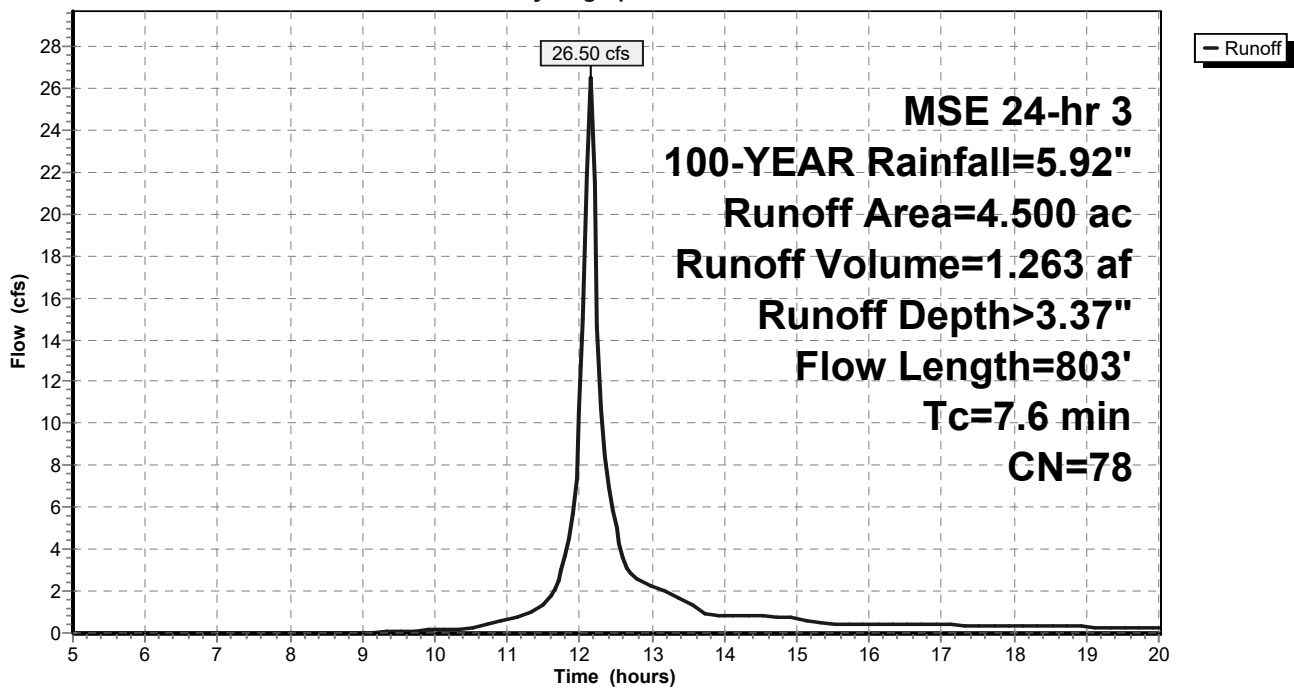

YORKVILLE

MSE 24-hr 3 100-YEAR Rainfall=5.92"

Prepared by {enter your company name here}

Printed 2/26/2021

HydroCAD® 10.00-22 s/n 07894 © 2018 HydroCAD Software Solutions LLC

Page 45

Summary for Subcatchment OFF: OFFSITE AREA

Runoff = 10.21 cfs @ 12.27 hrs, Volume= 0.675 af, Depth> 2.70"

Runoff by SCS TR-20 method, UH=SCS, Weighted-CN, Time Span= 5.00-20.00 hrs, dt= 0.05 hrs
MSE 24-hr 3 100-YEAR Rainfall=5.92"

Area (ac)	CN	Description
* 3.000	71	AG LANDS
3.000		100.00% Pervious Area

Tc (min)	Length (feet)	Slope (ft/ft)	Velocity (ft/sec)	Capacity (cfs)	Description
17.3	1,320	0.0200	1.27		Shallow Concentrated Flow, SHALLOW CONCENTRATED Cultivated Straight Rows Kv= 9.0 fps

Subcatchment OFF: OFFSITE AREA

Hydrograph

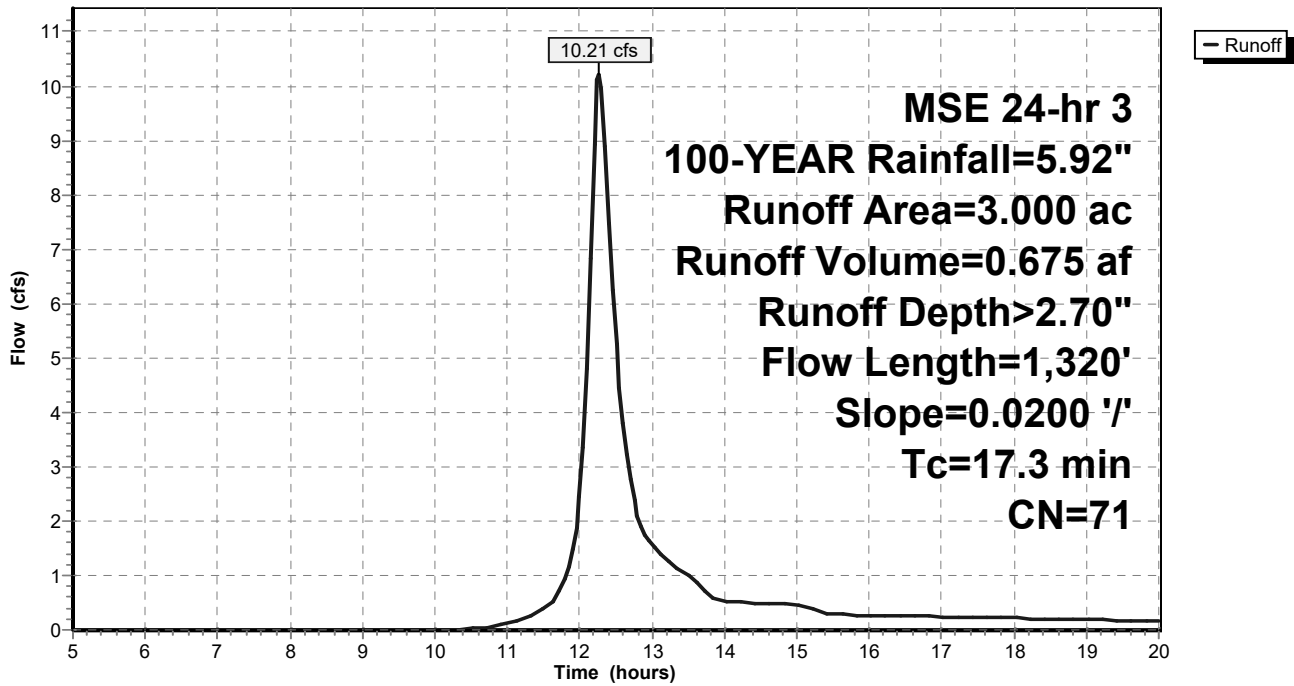

YORKVILLE

MSE 24-hr 3 100-YEAR Rainfall=5.92"

Prepared by {enter your company name here}

Printed 2/26/2021

HydroCAD® 10.00-22 s/n 07894 © 2018 HydroCAD Software Solutions LLC

Page 46

Summary for Subcatchment UND: UNDETAINED

Runoff = 11.18 cfs @ 12.13 hrs, Volume= 0.505 af, Depth> 3.37"

Runoff by SCS TR-20 method, UH=SCS, Weighted-CN, Time Span= 5.00-20.00 hrs, dt= 0.05 hrs
 MSE 24-hr 3 100-YEAR Rainfall=5.92"

Area (ac)	CN	Description
* 0.100	98	ROOF
* 0.200	98	PAVEMENT
* 1.500	74	GRASS
1.800	78	Weighted Average
1.500		83.33% Pervious Area
0.300		16.67% Impervious Area

Tc (min)	Length (feet)	Slope (ft/ft)	Velocity (ft/sec)	Capacity (cfs)	Description
6.0					Direct Entry, MIN PER TR-55

Subcatchment UND: UNDETAINED

Hydrograph

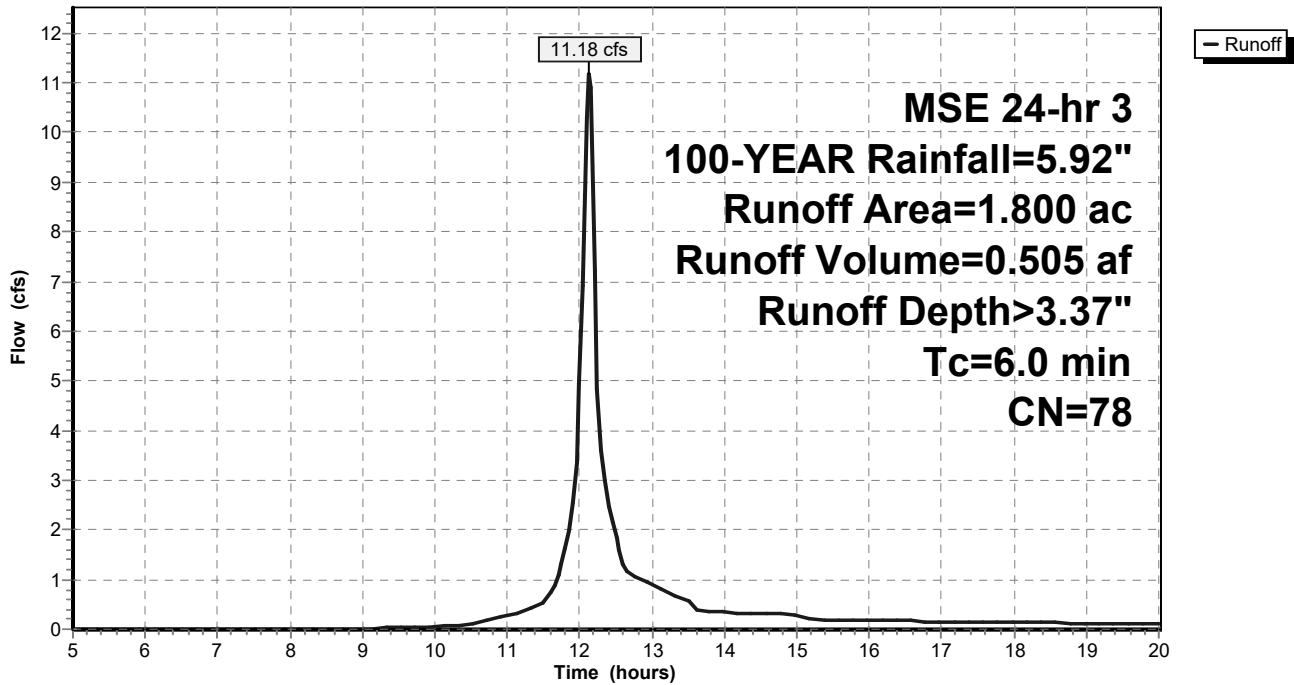

Summary for Pond MP: MIDDLE POND

Inflow Area = 5.200 ac, 19.23% Impervious, Inflow Depth > 3.47" for 100-YEAR event
 Inflow = 31.73 cfs @ 12.15 hrs, Volume= 1.502 af
 Outflow = 5.27 cfs @ 12.54 hrs, Volume= 1.251 af, Atten= 83%, Lag= 23.3 min
 Primary = 5.27 cfs @ 12.54 hrs, Volume= 1.251 af

Routing by Stor-Ind method, Time Span= 5.00-20.00 hrs, dt= 0.05 hrs
 Peak Elev= 718.66' @ 12.54 hrs Surf.Area= 15,315 sf Storage= 33,640 cf

Plug-Flow detention time= 107.0 min calculated for 1.251 af (83% of inflow)
 Center-of-Mass det. time= 65.0 min (842.1 - 777.1)

Volume	Invert	Avail.Storage	Storage Description
#1	716.00'	39,000 cf	Custom Stage Data (Prismatic) Listed below (Recalc)

Elevation (feet)	Surf.Area (sq-ft)	Inc.Store (cubic-feet)	Cum.Store (cubic-feet)
716.00	10,000	0	0
719.00	16,000	39,000	39,000

Device	Routing	Invert	Outlet Devices
#1	Primary	716.00'	12.0" Round Culvert L= 36.0' RCP, square edge headwall, Ke= 0.500 Inlet / Outlet Invert= 716.00' / 715.82' S= 0.0050 '/' Cc= 0.900 n= 0.013, Flow Area= 0.79 sf
#2	Device 1	716.00'	4.0" Vert. Orifice/Grate C= 0.600
#3	Device 1	717.00'	12.0" Horiz. Orifice/Grate C= 0.600 Limited to weir flow at low heads

Primary OutFlow Max=5.27 cfs @ 12.54 hrs HW=718.66' (Free Discharge)

- ↑ 1=Culvert (Barrel Controls 5.27 cfs @ 6.71 fps)
- ↑ 2=Orifice/Grate (Passes < 0.66 cfs potential flow)
- ↑ 3=Orifice/Grate (Passes < 4.87 cfs potential flow)

Pond MP: MIDDLE POND

Hydrograph

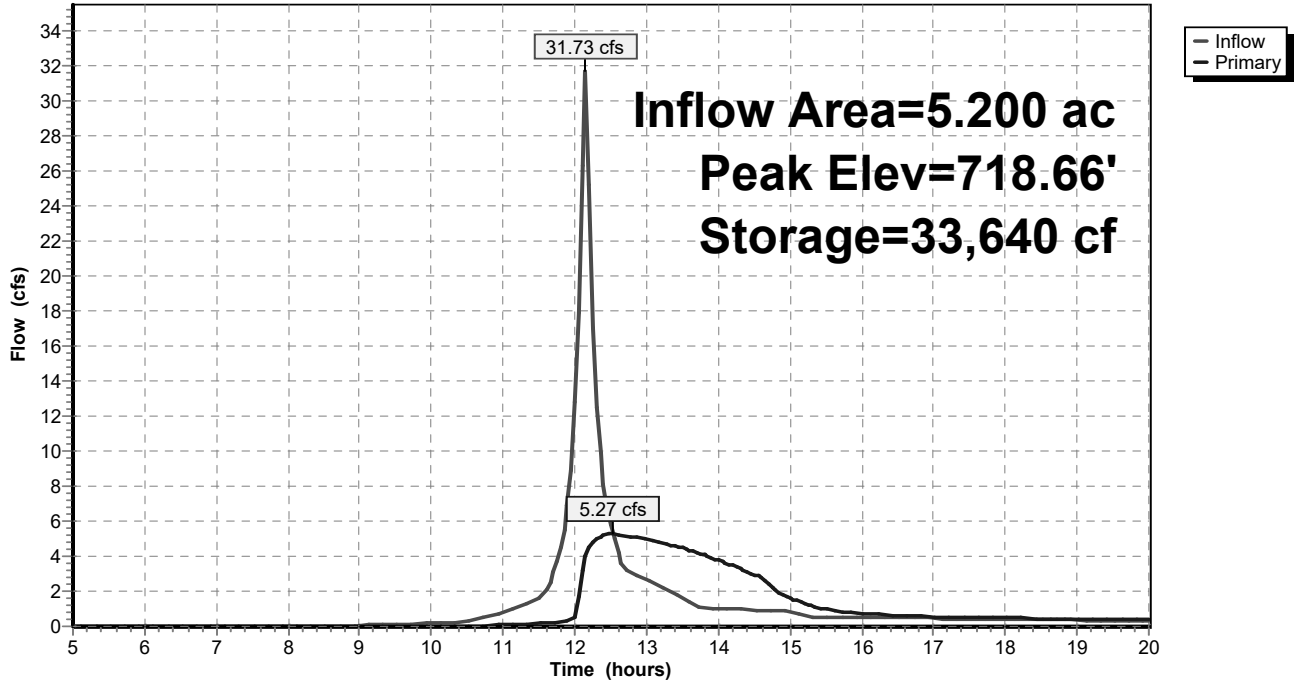

YORKVILLE

MSE 24-hr 3 100-YEAR Rainfall=5.92"

Prepared by {enter your company name here}

Printed 2/26/2021

HydroCAD® 10.00-22 s/n 07894 © 2018 HydroCAD Software Solutions LLC

Page 49

Summary for Pond NP: NORTH POND

Inflow Area = 21.400 ac, 9.35% Impervious, Inflow Depth > 3.19" for 100-YEAR event
 Inflow = 93.49 cfs @ 12.22 hrs, Volume= 5.681 af
 Outflow = 23.60 cfs @ 12.62 hrs, Volume= 4.531 af, Atten= 75%, Lag= 23.8 min
 Primary = 23.60 cfs @ 12.62 hrs, Volume= 4.531 af

Routing by Stor-Ind method, Time Span= 5.00-20.00 hrs, dt= 0.05 hrs
 Peak Elev= 719.53' @ 12.62 hrs Surf.Area= 47,165 sf Storage= 123,046 cf

Plug-Flow detention time= 113.1 min calculated for 4.516 af (79% of inflow)
 Center-of-Mass det. time= 67.7 min (854.1 - 786.4)

Volume	Invert	Avail.Storage	Storage Description
#1	716.00'	146,000 cf	Custom Stage Data (Prismatic) Listed below (Recalc)
Elevation (feet)	Surf.Area (sq-ft)	Inc.Store (cubic-feet)	Cum.Store (cubic-feet)
716.00	22,000	0	0
719.00	44,000	99,000	99,000
720.00	50,000	47,000	146,000

Device	Routing	Invert	Outlet Devices
#1	Primary	716.00'	24.0" Round Culvert L= 36.0' RCP, square edge headwall, Ke= 0.500 Inlet / Outlet Invert= 716.00' / 715.82' S= 0.0050 '/' Cc= 0.900 n= 0.013, Flow Area= 3.14 sf
#2	Device 1	716.00'	6.0" Vert. Orifice/Grate C= 0.600
#3	Device 1	717.50'	36.0" Vert. Orifice/Grate C= 0.600

Primary OutFlow Max=23.59 cfs @ 12.62 hrs HW=719.53' (Free Discharge)

- ↑ **1=Culvert** (Barrel Controls 23.59 cfs @ 7.51 fps)
- ↑ **2=Orifice/Grate** (Passes < 1.71 cfs potential flow)
- ↑ **3=Orifice/Grate** (Passes < 24.61 cfs potential flow)

Pond NP: NORTH POND

Hydrograph

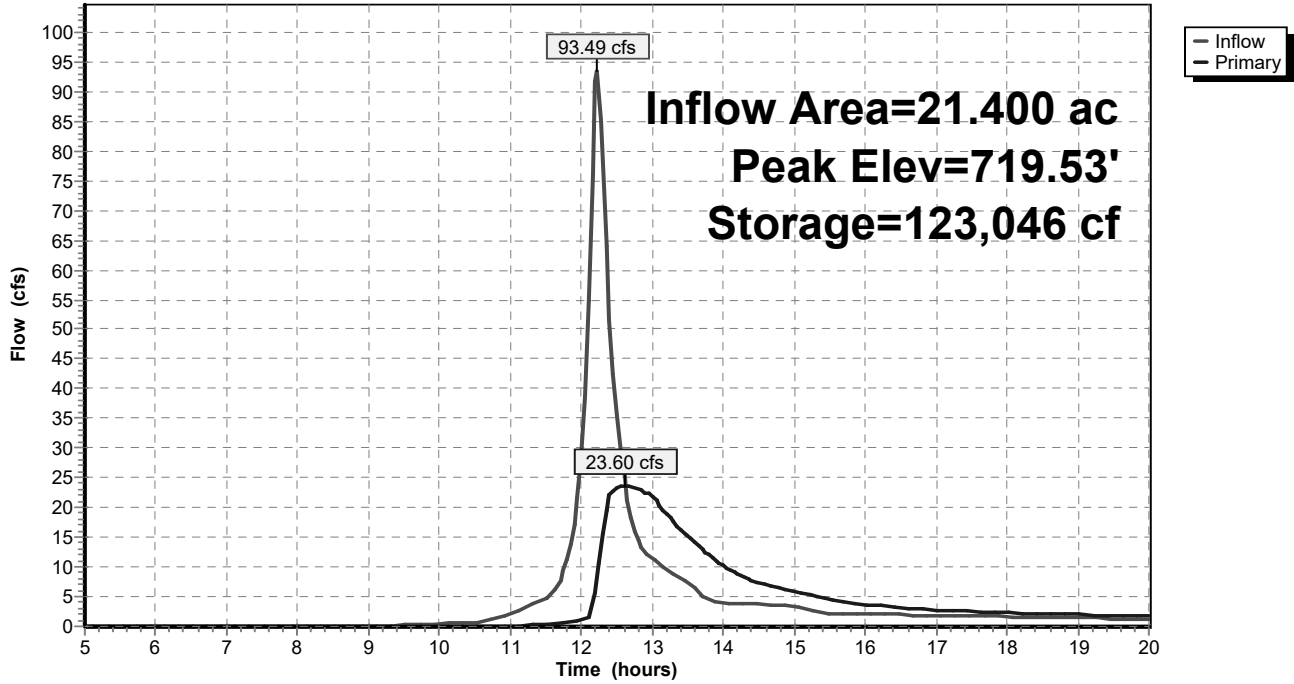

Summary for Pond SP: SOUTH POND

Inflow Area = 4.500 ac, 15.56% Impervious, Inflow Depth > 3.37" for 100-YEAR event
 Inflow = 26.50 cfs @ 12.15 hrs, Volume= 1.263 af
 Outflow = 4.81 cfs @ 12.51 hrs, Volume= 1.029 af, Atten= 82%, Lag= 21.9 min
 Primary = 4.81 cfs @ 12.51 hrs, Volume= 1.029 af

Routing by Stor-Ind method, Time Span= 5.00-20.00 hrs, dt= 0.05 hrs
 Peak Elev= 718.35' @ 12.51 hrs Surf.Area= 13,799 sf Storage= 27,756 cf

Plug-Flow detention time= 106.2 min calculated for 1.029 af (82% of inflow)
 Center-of-Mass det. time= 61.8 min (840.4 - 778.6)

Volume	Invert	Avail.Storage	Storage Description
#1	716.00'	37,050 cf	Custom Stage Data (Prismatic) Listed below (Recalc)

Elevation (feet)	Surf.Area (sq-ft)	Inc.Store (cubic-feet)	Cum.Store (cubic-feet)
716.00	9,800	0	0
719.00	14,900	37,050	37,050

Device	Routing	Invert	Outlet Devices
#1	Primary	716.00'	12.0" Round Culvert L= 36.0' RCP, square edge headwall, Ke= 0.500 Inlet / Outlet Invert= 716.00' / 715.82' S= 0.0050 '/' Cc= 0.900 n= 0.013, Flow Area= 0.79 sf
#2	Device 1	716.00'	4.0" Vert. Orifice/Grate C= 0.600
#3	Device 1	717.00'	12.0" Horiz. Orifice/Grate C= 0.600 Limited to weir flow at low heads

Primary OutFlow Max=4.81 cfs @ 12.51 hrs HW=718.35' (Free Discharge)

- ↑ 1=Culvert (Barrel Controls 4.81 cfs @ 6.12 fps)
- ↑ 2=Orifice/Grate (Passes < 0.62 cfs potential flow)
- ↑ 3=Orifice/Grate (Passes < 4.40 cfs potential flow)

Pond SP: SOUTH POND

Hydrograph

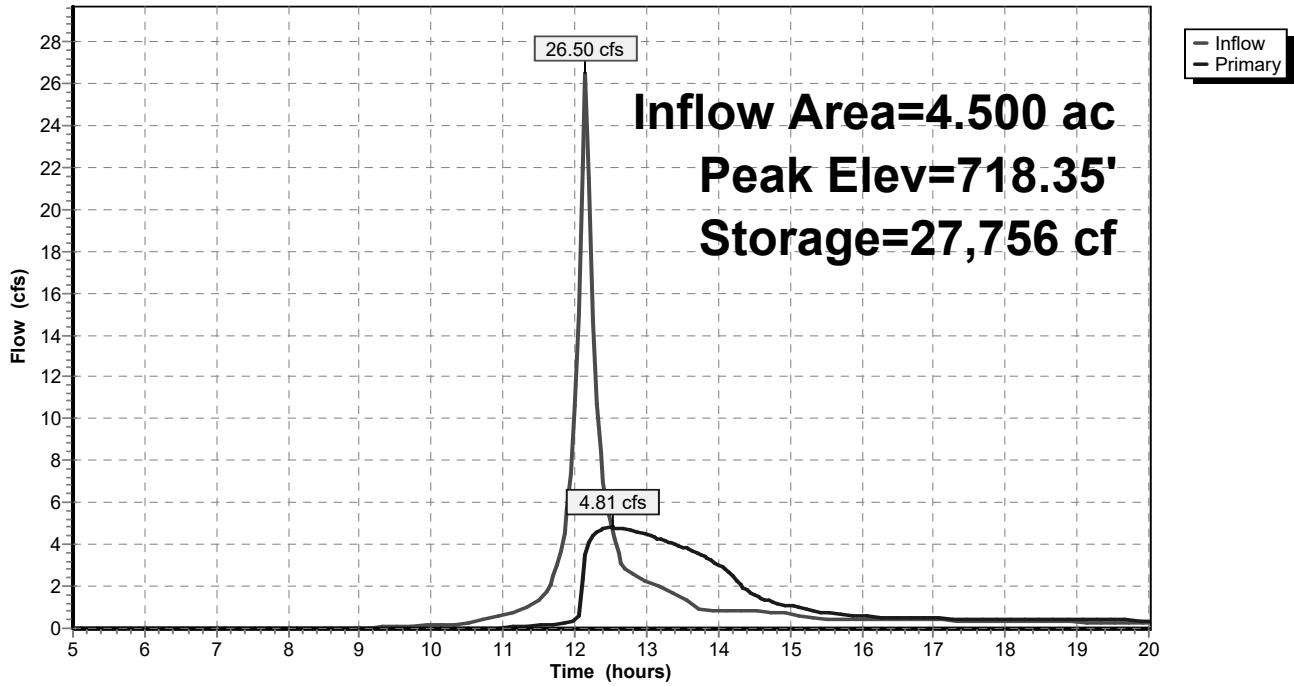

Summary for Link PSD: PROPOSED SITE DISCHARGE

Inflow Area = 32.900 ac, 12.16% Impervious, Inflow Depth > 2.67" for 100-YEAR event
Inflow = 35.18 cfs @ 12.53 hrs, Volume= 7.317 af
Primary = 35.18 cfs @ 12.53 hrs, Volume= 7.317 af, Atten= 0%, Lag= 0.0 min

Primary outflow = Inflow, Time Span= 5.00-20.00 hrs, dt= 0.05 hrs

Link PSD: PROPOSED SITE DISCHARGE

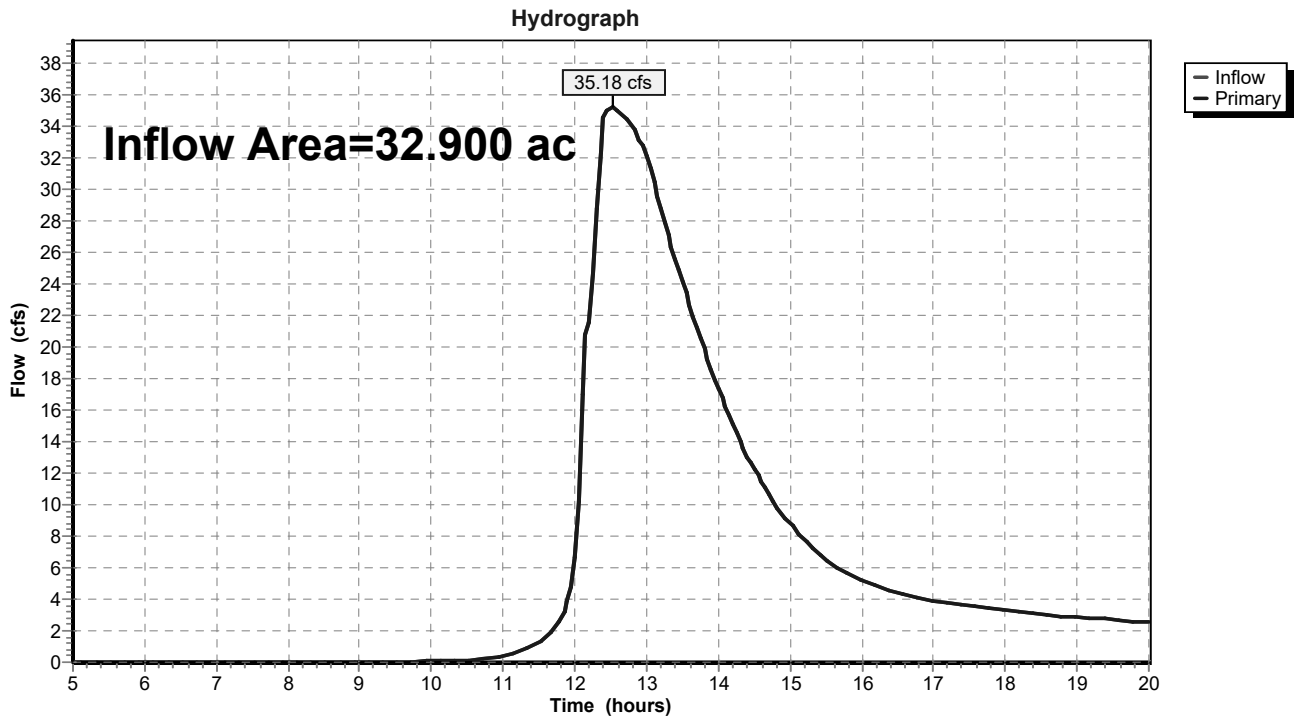

APPENDIX 4

POST-DEVELOPMENT CONDITIONS INFORMATION (WATER QUALITY)

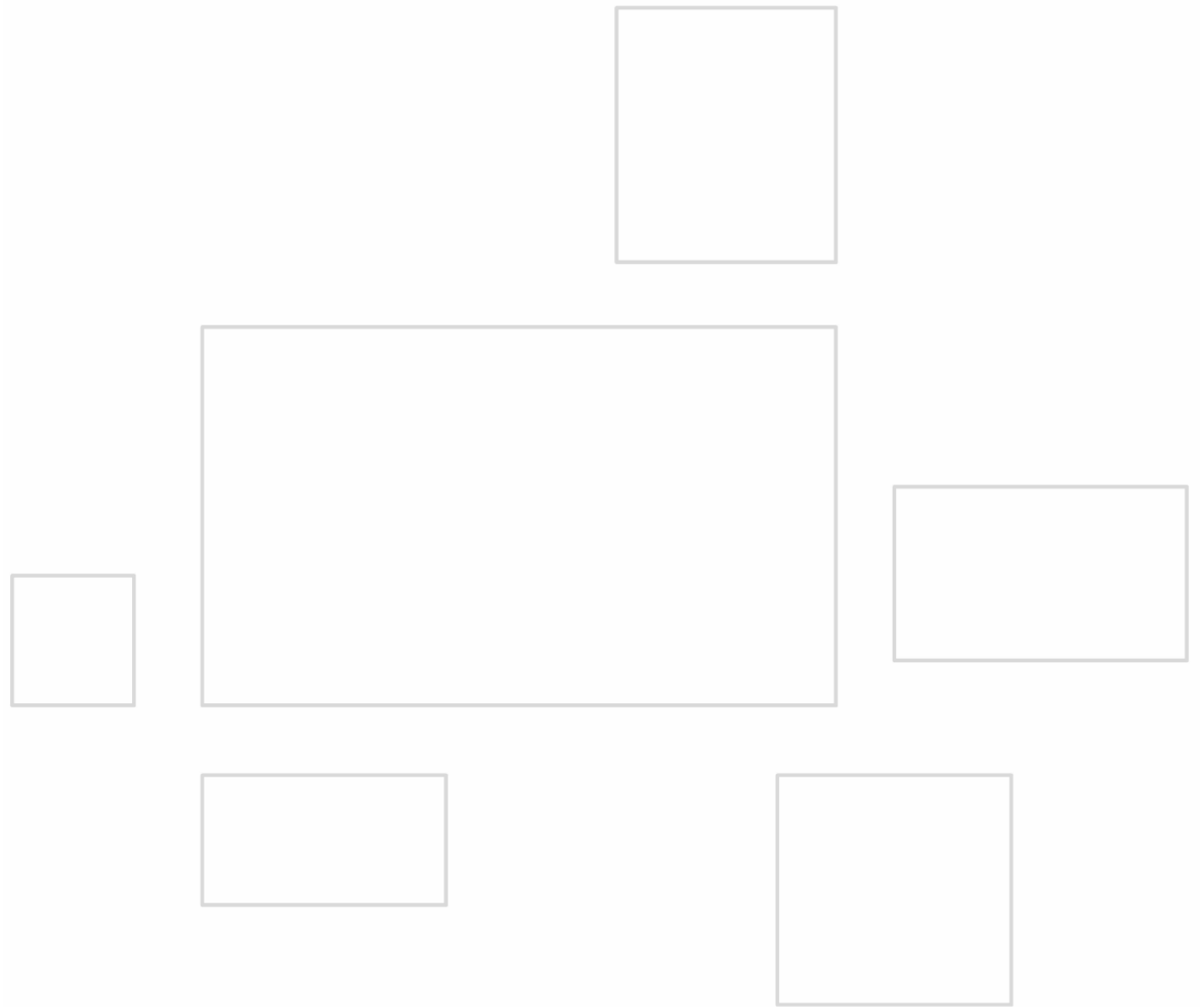

SLAMM NODE LAYOUT

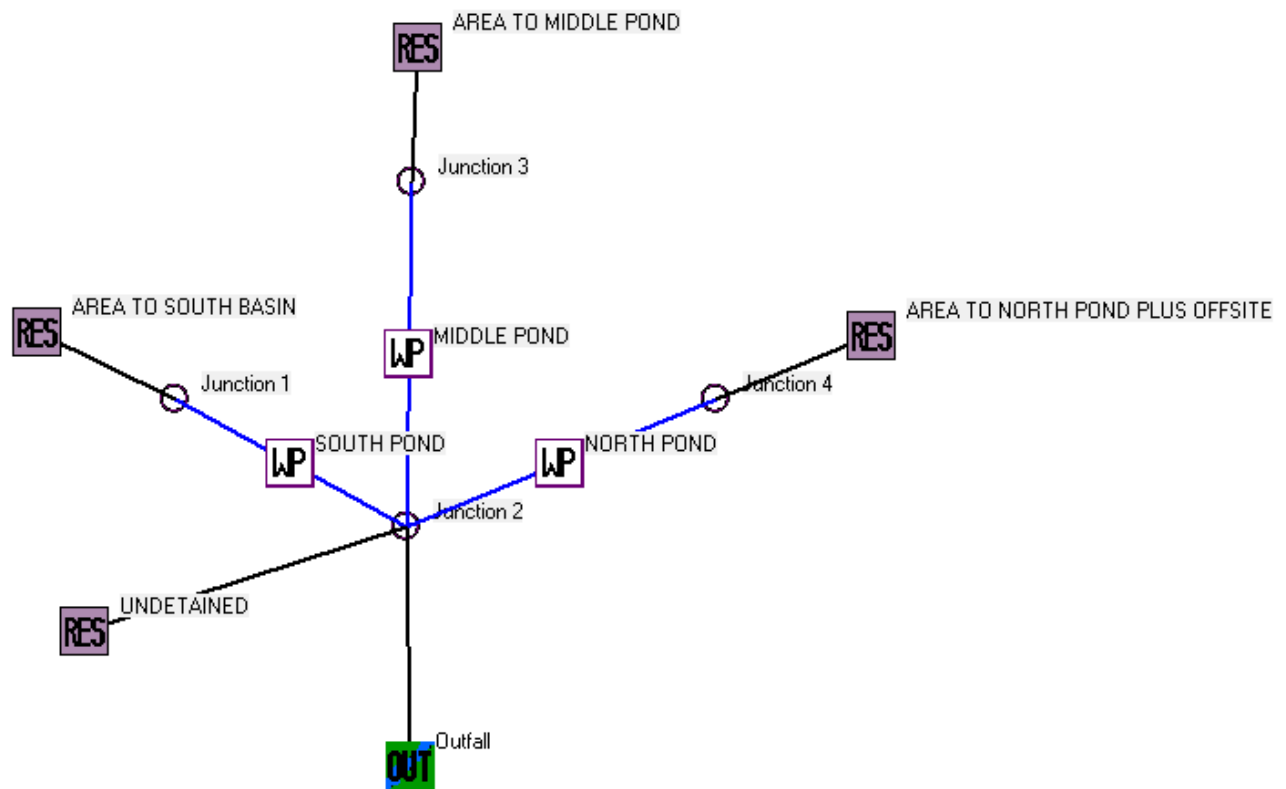

Data file name: Z:\Projects\2018\1335.00-WI\DESIGN\SWMP\SLAMM\YORKVILLE.mdb
 WinSLAMM Version 10.4.1
 Rain file name: C:\WinSLAMM Files\Rain Files\WI Milwaukee 69.RAN
 Particulate Solids Concentration file name: C:\WinSLAMM Files\10.1 WI_AVG01.pscx
 Runoff Coefficient file name: C:\WinSLAMM Files\WI_SL06 Dec06.rsvx
 Residential Street Delivery file name: C:\WinSLAMM Files\WI_Res and Other Urban Dec06.std
 Institutional Street Delivery file name: C:\WinSLAMM Files\WI_Com Inst Indust Dec06.std
 Commercial Street Delivery file name: C:\WinSLAMM Files\WI_Com Inst Indust Dec06.std
 Industrial Street Delivery file name: C:\WinSLAMM Files\WI_Com Inst Indust Dec06.std
 Other Urban Street Delivery file name: C:\WinSLAMM Files\WI_Res and Other Urban Dec06.std
 Freeway Street Delivery file name: C:\WinSLAMM Files\Freeway Dec06.std
 Apply Street Delivery Files to Adjust the After Event Load Street Dirt Mass Balance: False
 Pollutant Relative Concentration file name: C:\WinSLAMM Files\WI_GEO03.ppdx
 Source Area PSD and Peak to Average Flow Ratio File: C:\WinSLAMM Files\NURP Source Area PSD Files.csv
 Cost Data file name:
 Seed for random number generator: -42
 Study period starting date: 01/05/69 Study period ending date: 12/31/69
 Start of Winter Season: 12/06 End of Winter Season: 03/28
 Date: 02-24-2021 Time: 17:26:52
 Site information: YORKVILLE

LU# 1 - Residential: AREA TO SOUTH BASIN Total area (ac): 4.500
 1 - Roofs 1: 0.300 ac. Pitched Connected PSD File: C:\WinSLAMM Files\NURP.cpz
 13 - Paved Parking 1: 0.200 ac. Connected PSD File: C:\WinSLAMM Files\NURP.cpz
 45 - Large Landscaped Areas 1: 3.800 ac. Normal Clayey PSD File: C:\WinSLAMM Files\NURP.cpz
 70 - Water Body Areas: 0.200 ac. PSD File:

LU# 2 - Residential: AREA TO MIDDLE POND Total area (ac): 5.200
 1 - Roofs 1: 0.300 ac. Pitched Connected PSD File: C:\WinSLAMM Files\NURP.cpz
 13 - Paved Parking 1: 0.500 ac. Connected PSD File: C:\WinSLAMM Files\NURP.cpz
 45 - Large Landscaped Areas 1: 4.200 ac. Normal Clayey PSD File: C:\WinSLAMM Files\NURP.cpz
 70 - Water Body Areas: 0.200 ac. PSD File:

LU# 3 - Residential: AREA TO NORTH POND PLUS OFFSITE Total area (ac): 21.400
 1 - Roofs 1: 0.800 ac. Pitched Connected PSD File: C:\WinSLAMM Files\NURP.cpz
 13 - Paved Parking 1: 0.700 ac. Connected PSD File: C:\WinSLAMM Files\NURP.cpz
 45 - Large Landscaped Areas 1: 16.400 ac. Normal Clayey PSD File: C:\WinSLAMM Files\NURP.cpz
 46 - Large Landscaped Areas 2: 3.000 ac. Normal Clayey PSD File: C:\WinSLAMM Files\NURP.cpz
 70 - Water Body Areas: 0.500 ac. PSD File:

LU# 4 - Residential: UNDETAINED Total area (ac): 1.800
 1 - Roofs 1: 0.100 ac. Pitched Connected PSD File: C:\WinSLAMM Files\NURP.cpz
 13 - Paved Parking 1: 0.200 ac. Connected PSD File: C:\WinSLAMM Files\NURP.cpz
 45 - Large Landscaped Areas 1: 1.500 ac. Normal Clayey PSD File: C:\WinSLAMM Files\NURP.cpz

Control Practice 1: Wet Detention Pond CP# 1 (DS) - SOUTH POND
 Particle Size Distribution file name: Not needed - calculated by program
 Initial stage elevation (ft): 5
 Peak to Average Flow Ratio: 3.8
 Maximum flow allowed into pond (cfs): No maximum value entered
 Outlet Characteristics:

- Outlet type: Orifice 1
 1. Orifice diameter (ft): 0.33
 2. Number of orifices: 1
 3. Invert elevation above datum (ft): 5
- Outlet type: Broad Crested Weir
 1. Weir crest length (ft): 10
 2. Weir crest width (ft): 10
 3. Height from datum to bottom of weir opening: 7.99
- Outlet type: Vertical Stand Pipe
 1. Stand pipe diameter (ft): 1
 2. Stand pipe height above datum (ft): 6

Pond stage and surface area

Entry Number	Stage (ft)	Pond Area (acres)	Natural Seepage (in/hr)	Other Outflow (cfs)
0	0.00	0.0000	0.00	0.00
1	0.01	0.0700	0.00	0.00
2	1.00	0.0900	0.00	0.00
3	4.00	0.1500	0.00	0.00
4	5.00	0.2200	0.00	0.00
5	8.00	0.3400	0.00	0.00

Control Practice 2: Wet Detention Pond CP# 2 (DS) - MIDDLE POND

Particle Size Distribution file name: Not needed - calculated by program

Initial stage elevation (ft): 5

Peak to Average Flow Ratio: 3.8

Maximum flow allowed into pond (cfs): No maximum value entered

Outlet Characteristics:

Outlet type: Orifice 1

1. Orifice diameter (ft): 0.33
2. Number of orifices: 1
3. Invert elevation above datum (ft): 5

Outlet type: Broad Crested Weir

1. Weir crest length (ft): 10
2. Weir crest width (ft): 10
3. Height from datum to bottom of weir opening: 7.99

Outlet type: Vertical Stand Pipe

1. Stand pipe diameter (ft): 1
2. Stand pipe height above datum (ft): 6

Pond stage and surface area

Entry Number	Stage (ft)	Pond Area (acres)	Natural Seepage (in/hr)	Other Outflow (cfs)
0	0.00	0.0000	0.00	0.00
1	0.01	0.0600	0.00	0.00
2	1.00	0.0700	0.00	0.00
3	4.00	0.1400	0.00	0.00
4	5.00	0.2300	0.00	0.00
5	8.00	0.3700	0.00	0.00

Control Practice 3: Wet Detention Pond CP# 3 (DS) - NORTH POND

Particle Size Distribution file name: Not needed - calculated by program

Initial stage elevation (ft): 5

Peak to Average Flow Ratio: 3.8

Maximum flow allowed into pond (cfs): No maximum value entered

Outlet Characteristics:

Outlet type: Orifice 1

1. Orifice diameter (ft): 0.33
2. Number of orifices: 1
3. Invert elevation above datum (ft): 5

Outlet type: Broad Crested Weir

1. Weir crest length (ft): 20
2. Weir crest width (ft): 20
3. Height from datum to bottom of weir opening: 8.5

Outlet type: Vertical Stand Pipe

1. Stand pipe diameter (ft): 3
2. Stand pipe height above datum (ft): 6.5

Pond stage and surface area

Entry Number	Stage (ft)	Pond Area (acres)	Natural Seepage (in/hr)	Other Outflow (cfs)
0	0.00	0.0000	0.00	0.00
1	0.01	0.1600	0.00	0.00
2	1.00	0.1900	0.00	0.00
3	4.00	0.3100	0.00	0.00
4	5.00	0.5000	0.00	0.00
5	8.00	1.0100	0.00	0.00
6	9.00	1.1500	0.00	0.00

Data file name: Z:\Projects\2018\1335.00-W\DESIGN\SWMP\SLAMM\YORKVILLE.mdb
WinSLAMM Version 10.4.1
Rain file name: C:\WinSLAMM Files\Rain Files\WI Milwaukee 69.RAN
Particulate Solids Concentration file name: C:\WinSLAMM Files\v10.1 WI_AVG01.pscx
Runoff Coefficient file name: C:\WinSLAMM Files\WI_SL06 Dec06.rsvx
Pollutant Relative Concentration file name: C:\WinSLAMM Files\WI_GEO03.ppdx
Residential Street Delivery file name: C:\WinSLAMM Files\WI_Res and Other Urban Dec06.std
Institutional Street Delivery file name: C:\WinSLAMM Files\WI_Com Inst Indust Dec06.std
Commercial Street Delivery file name: C:\WinSLAMM Files\WI_Com Inst Indust Dec06.std
Industrial Street Delivery file name: C:\WinSLAMM Files\WI_Com Inst Indust Dec06.std
Other Urban Street Delivery file name: C:\WinSLAMM Files\WI_Res and Other Urban Dec06.std
Freeway Street Delivery file name: C:\WinSLAMM Files\Freeway Dec06.std
Apply Street Delivery Files to Adjust the After Event Load Street Dirt Mass Balance: False
Source Area PSD and Peak to Average Flow Ratio File: C:\WinSLAMM Files\NURP Source Area PSD Files.csv
Cost Data file name:
Seed for random number generator: -42
Study period starting date: 01/05/69 Study period ending date: 12/31/69
Start of Winter Season: 12/06 End of Winter Season: 03/28
Model Run Start Date: 01/05/69 Model Run End Date: 12/31/69
Date of run: 02-24-2021 Time of run: 17:30:37
Total Area Modeled (acres): 32.900
Years in Model Run: 0.99

	Runoff Volume (cu ft)	Percent Runoff Volume Reduction	Particulate Solids Conc. (mg/L)	Particulate Solids Yield (lbs)	Percent Particulate Solids Reduction
Total of all Land Uses without Controls:	580543	-	121.8	4415	-
Outfall Total with Controls:	581032	-0.08%	21.33	773.5	82.48%
Annualized Total After Outfall Controls:	589102			784.3	

Data file name: Z:\Projects\2018\1335.00-WI\DESIGN\SWMP\SLAMM\YORKVILLE.mdb

WinSLAMM Version 10.4.0

Rain file name: C:\WinSLAMM Files\Rain Files\WI Milwaukee 69.RAN

Particulate Solids Concentration file name: C:\WinSLAMM Files\v10.1 WI_AVG01.pscx

Runoff Coefficient file name: C:\WinSLAMM Files\WI_SL06 Dec06.rsvx

Residential Street Delivery file name: C:\WinSLAMM Files\WI_Res and Other Urban Dec06.std

Institutional Street Delivery file name: C:\WinSLAMM Files\WI_Com Inst Indust Dec06.std

Commercial Street Delivery file name: C:\WinSLAMM Files\WI_Com Inst Indust Dec06.std

Industrial Street Delivery file name: C:\WinSLAMM Files\WI_Com Inst Indust Dec06.std

Other Urban Street Delivery file name: C:\WinSLAMM Files\WI_Res and Other Urban Dec06.std

Freeway Street Delivery file name: C:\WinSLAMM Files\Freeway Dec06.std

Apply Street Delivery Files to Adjust the After Event Load Street Dirt Mass Balance: False

Pollutant Relative Concentration file name: C:\WinSLAMM Files\WI_GEO03.ppdx

Source Area PSD and Peak to Average Flow Ratio File: C:\WinSLAMM Files\NURP Source Area PSD Files.csv

Cost Data file name:

If Other Device Pollutant Load Reduction Values = 1, Off-site Pollutant Loads are Removed from Pollutant Load % Reduction calculations

Seed for random number generator: -42

Study period starting date: 01/05/69

Study period ending date: 12/31/69

Start of Winter Season: 12/06

End of Winter Season: 03/28

Date: 01-13-2021

Time: 05:23:31

Site information:

YORKVILLE

LU# 1 - Residential: AREA TO SOUTH BASIN Total area (ac): 4.500

1 - Roofs 1: 0.300 ac. Pitched Connected Source Area PSD File: C:\WinSLAMM Files\NURP.cpz

13 - Paved Parking 1: 0.200 ac. Connected Source Area PSD File: C:\WinSLAMM Files\NURP.cpz

45 - Large Landscaped Areas 1: 3.800 ac. Normal Clayey Source Area PSD File: C:\WinSLAMM

Files\NURP.cpz

70 - Water Body Areas: 0.200 ac. Source Area PSD File:

LU# 2 - Residential: AREA TO MIDDLE POND Total area (ac): 5.200

1 - Roofs 1: 0.300 ac. Pitched Connected Source Area PSD File: C:\WinSLAMM Files\NURP.cpz

13 - Paved Parking 1: 0.500 ac. Connected Source Area PSD File: C:\WinSLAMM Files\NURP.cpz

45 - Large Landscaped Areas 1: 4.200 ac. Normal Clayey Source Area PSD File: C:\WinSLAMM

Files\NURP.cpz

70 - Water Body Areas: 0.200 ac. Source Area PSD File:

LU# 3 - Residential: AREA TO NORTH POND PLUS OFFSITE Total area (ac): 21.400

1 - Roofs 1: 0.800 ac. Pitched Connected Source Area PSD File: C:\WinSLAMM Files\NURP.cpz

13 - Paved Parking 1: 0.700 ac. Connected Source Area PSD File: C:\WinSLAMM Files\NURP.cpz

45 - Large Landscaped Areas 1: 16.400 ac. Normal Clayey Source Area PSD File: C:\WinSLAMM

Files\NURP.cpz

46 - Large Landscaped Areas 2: 3.000 ac. Normal Clayey Source Area PSD File: C:\WinSLAMM

Files\NURP.cpz

70 - Water Body Areas: 0.500 ac. Source Area PSD File:

LU# 4 - Residential: UNDETAINED Total area (ac): 1.800

1 - Roofs 1: 0.100 ac. Pitched Connected Source Area PSD File: C:\WinSLAMM Files\NURP.cpz

APPENDIX 5 GEOTECHNICAL DATA

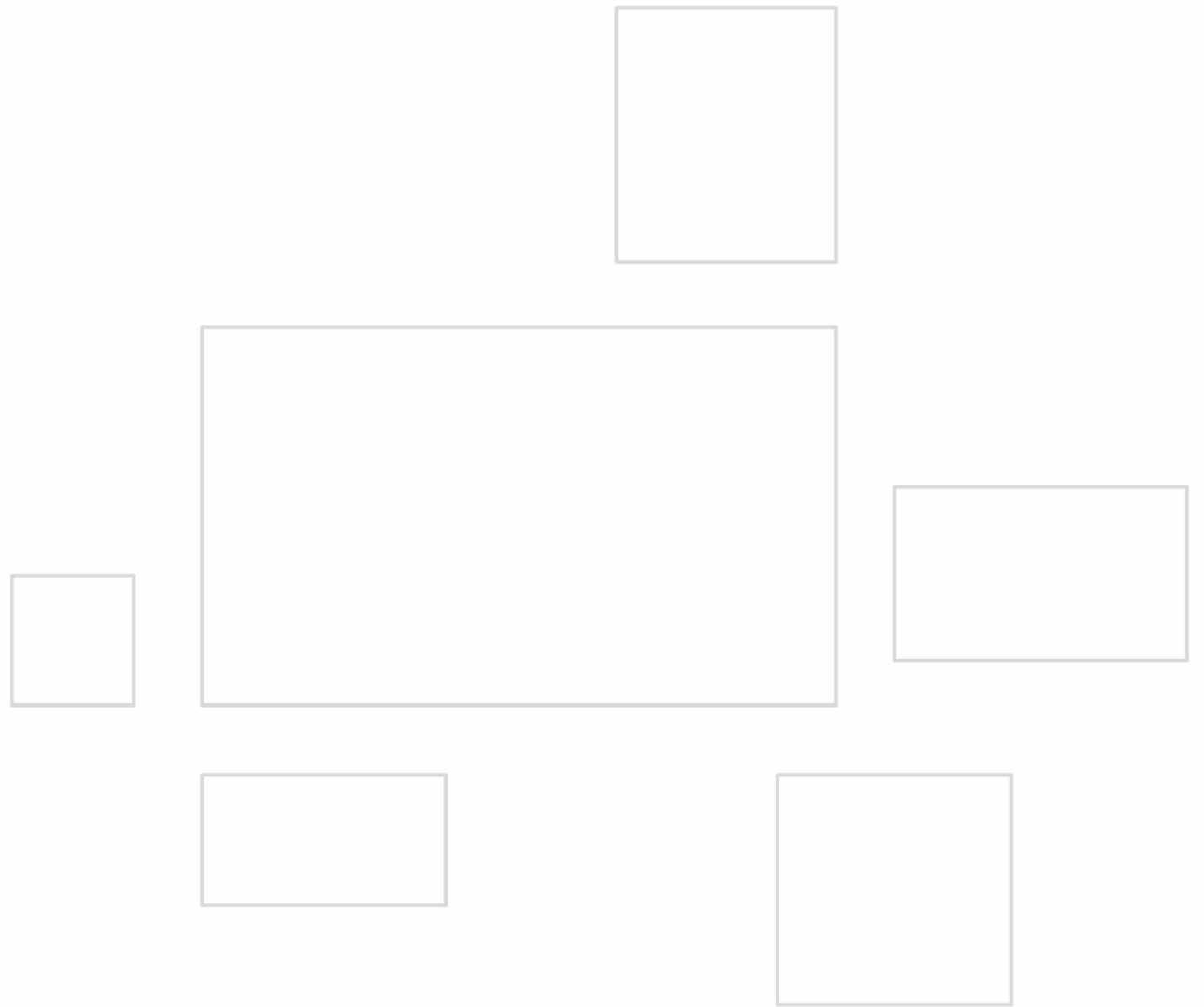

PLOT PLAN



Steve Johnson
 #227039
 November 8, 2018

Scale 1"=30'

 BM=100.0'
 B1=101.3'
 B2=101.3'
 B3=100.7'

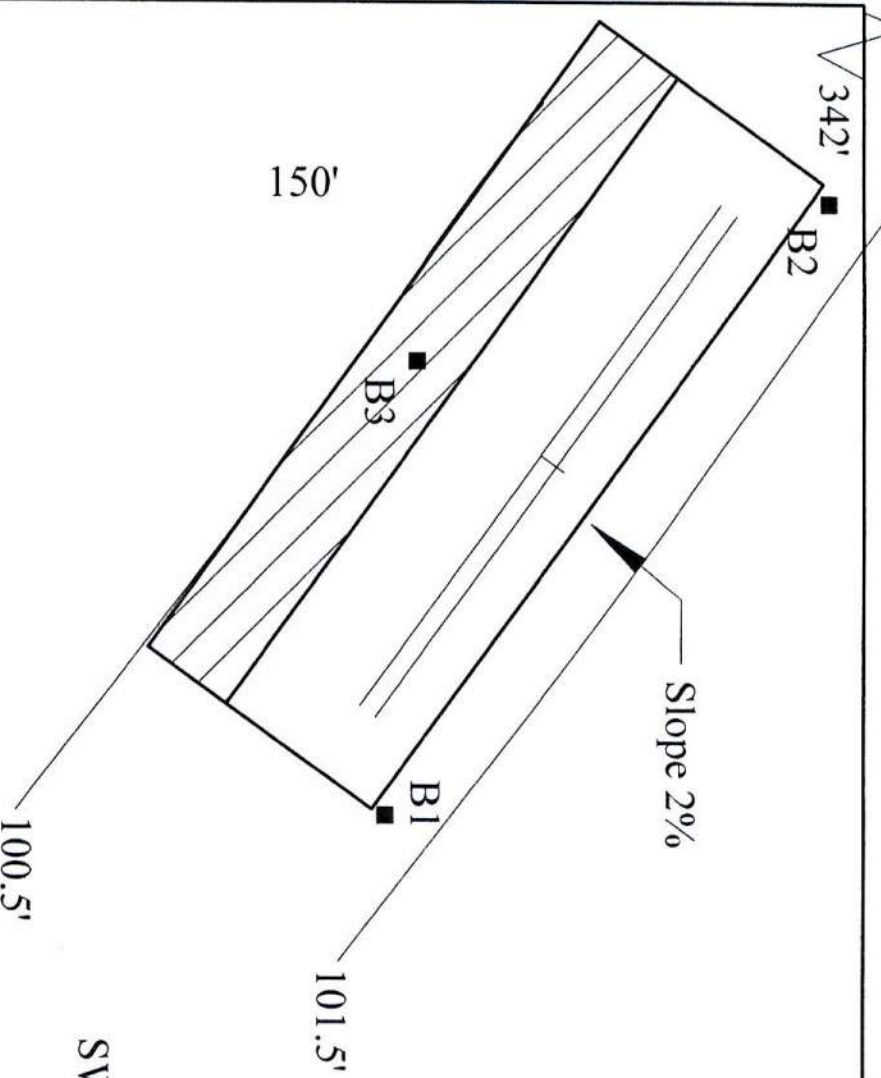
Newport Development
 Lot #1
 SW 1/4, Section 1, T3N-R21E
 Yorkville, Racine



Proposed Road 150' R.O.W.

60' to 50th Road



BM is top of bridge guardrail post 371' west

50Th Road R.O.W.

PLOT PLAN

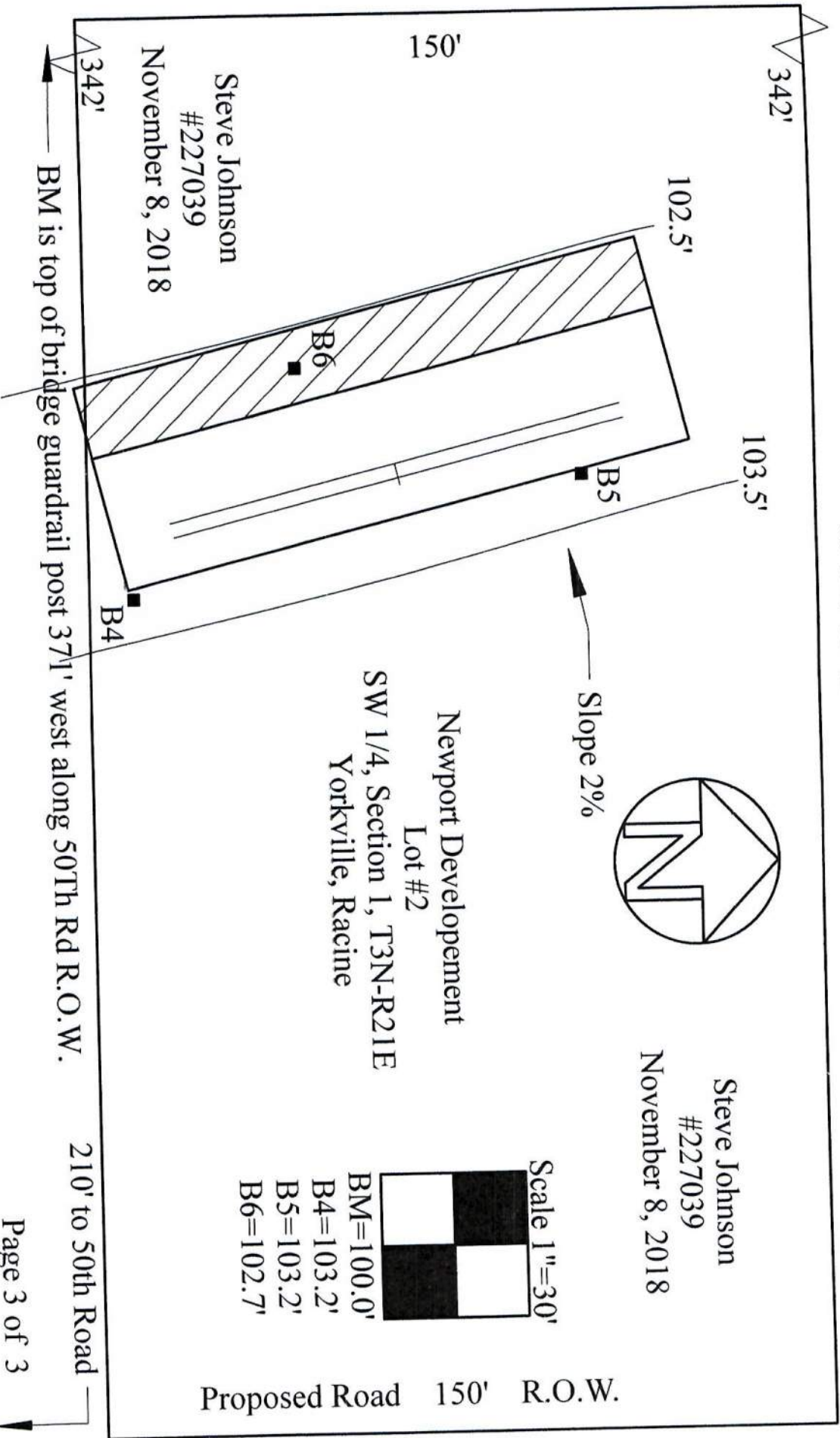

Steve Johnson
#227039
November 8, 2018

Steve Johnson
#227039
November 8, 2018

Newport Development
Lot #2
SW 1/4, Section 1, T3N-R21E
Yorkville, Racine

Scale 1"=30'

BM=100.0'	
B4=103.2'	
B5=103.2'	
B6=102.7'	

BM is top of bridge guardrail post 371' west along 50th Rd R.O.W.

Proposed Road 150' R.O.W.

210' to 50th Road

PLOT PLAN

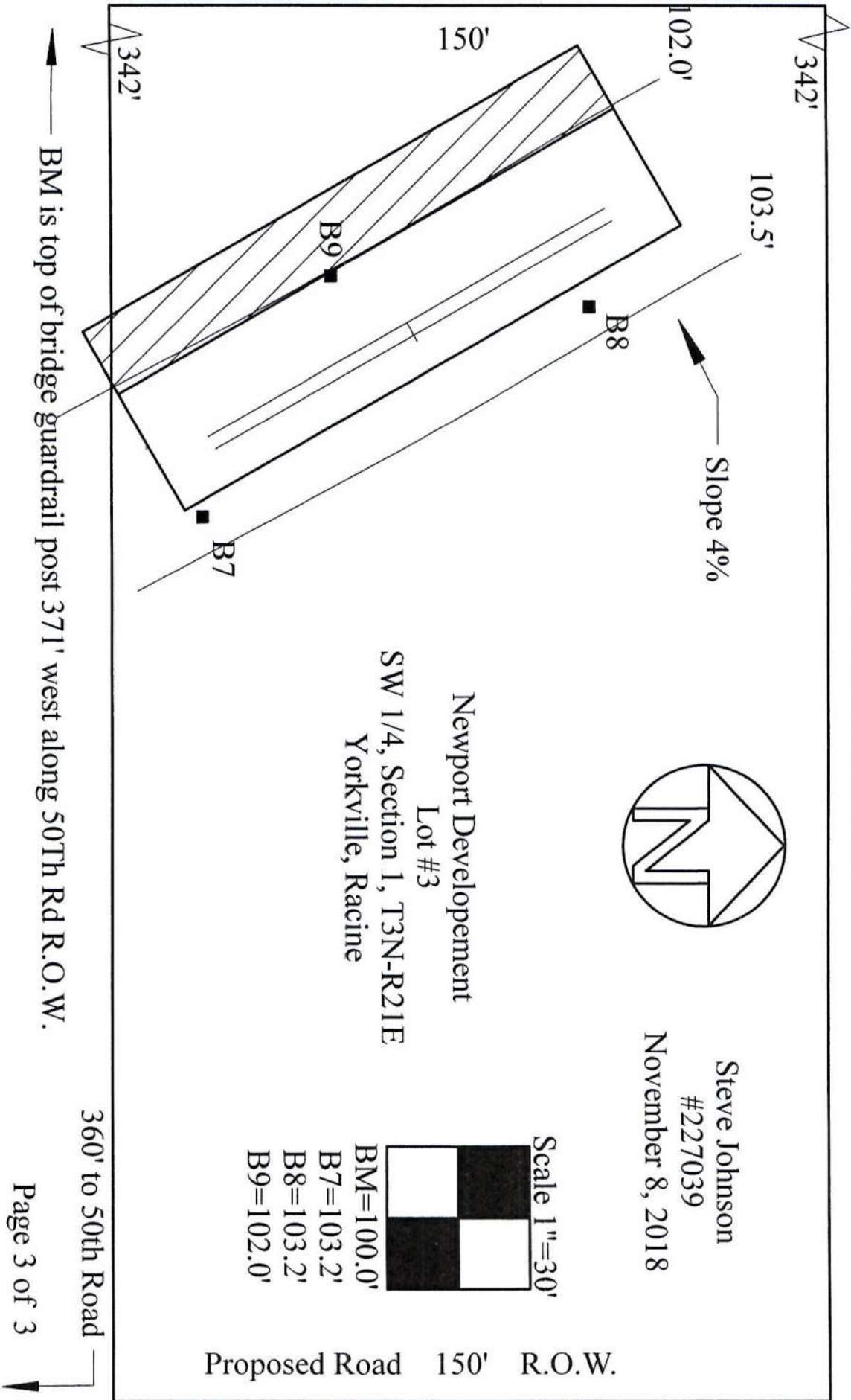

BM is top of bridge guardrail post 371' west along 50Th Rd R.O.W.

Proposed Road 150' R.O.W.

360' to 50th Road

Scale 1"=30'
BM=100.0'
B7=103.2'
B8=103.2'
B9=102.0'

Steve Johnson
#227039
November 8, 2018

Newport Development
Lot #3
SW 1/4, Section 1, T3N-R21E
Yorkville, Racine

PLOT PLAN

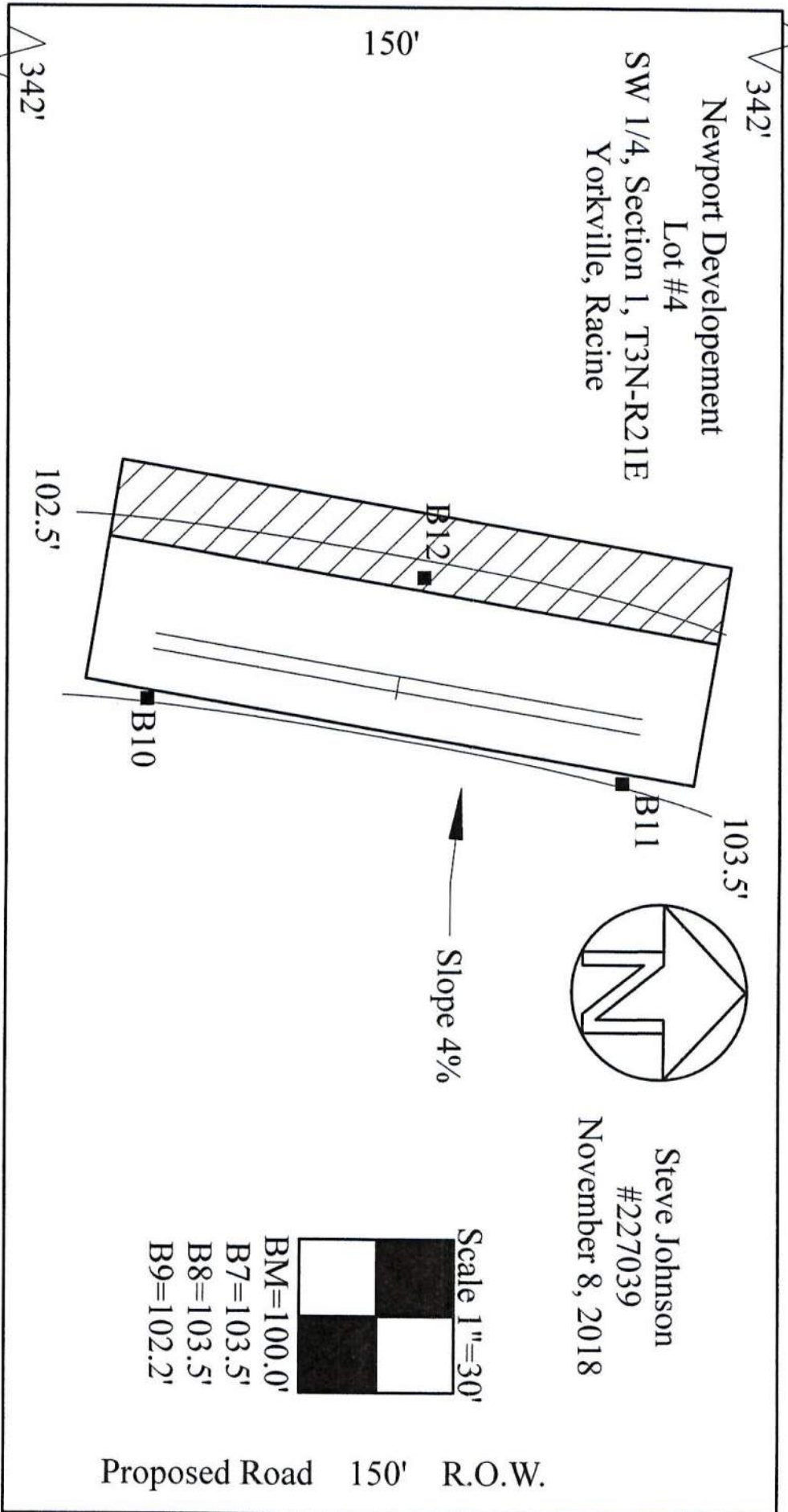

BM is top of bridge guardrail post 371' west along 50th Rd R.O.W.

100' PLOT PLAN

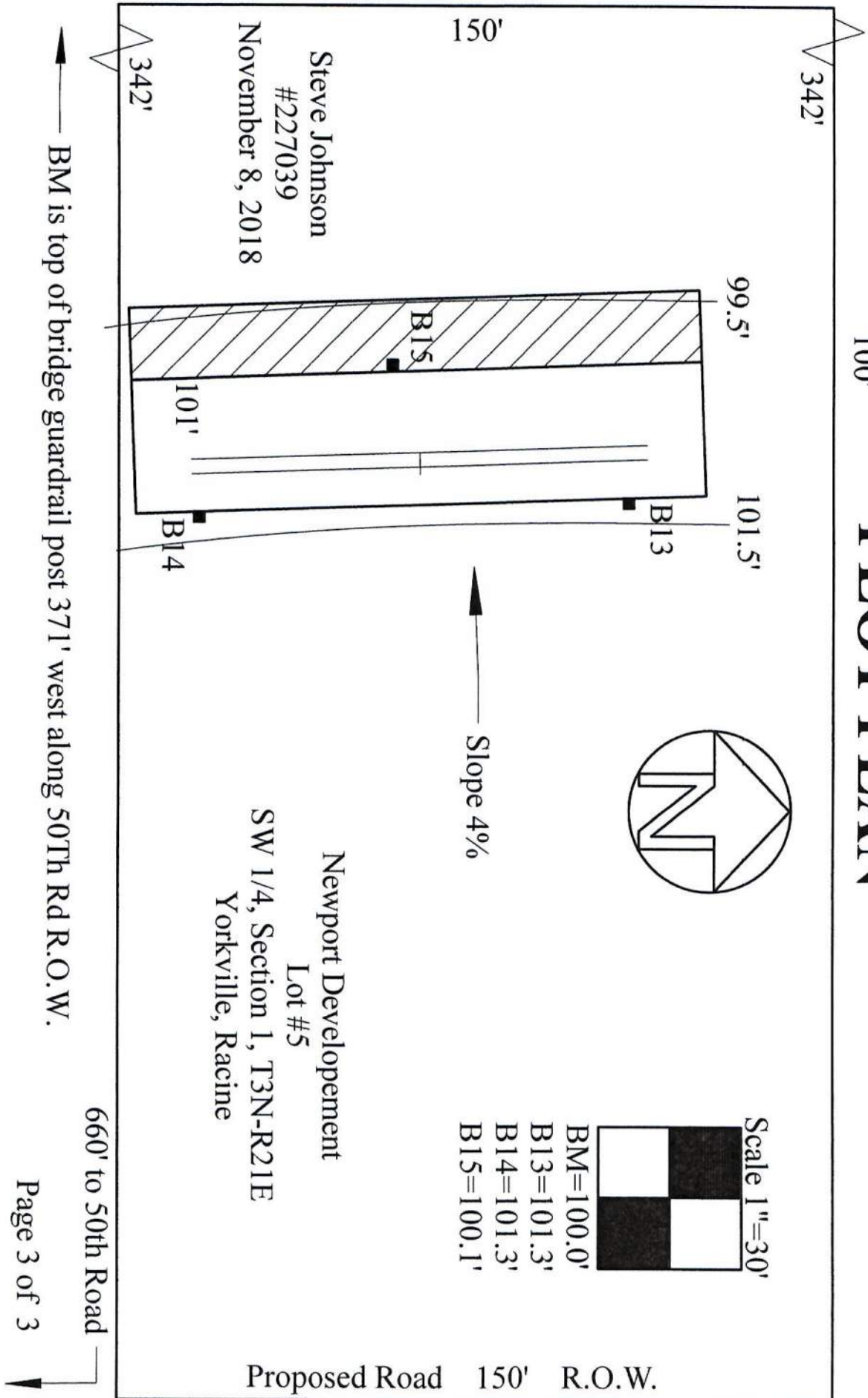

100'

PLOT PLAN

342'

Steve Johnson
#227039
November 8, 2018

150'

342'

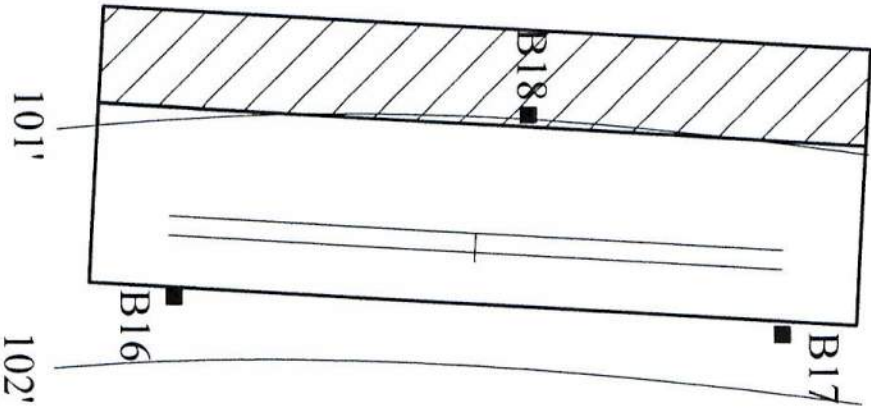

Slope 2.5%



Scale 1"=30'

BM=100.0'
B16=101.7'
B17=101.7'
B18=101.0'

Newport Development
Lot #6
SW 1/4, Section 1, T3N-R21E
Yorkville, Racine

Proposed Road 150' R.O.W.

BM is top of bridge guardrail post 371' west along 50Th Rd R.O.W.

810' to 50th Road

PLOT PLAN

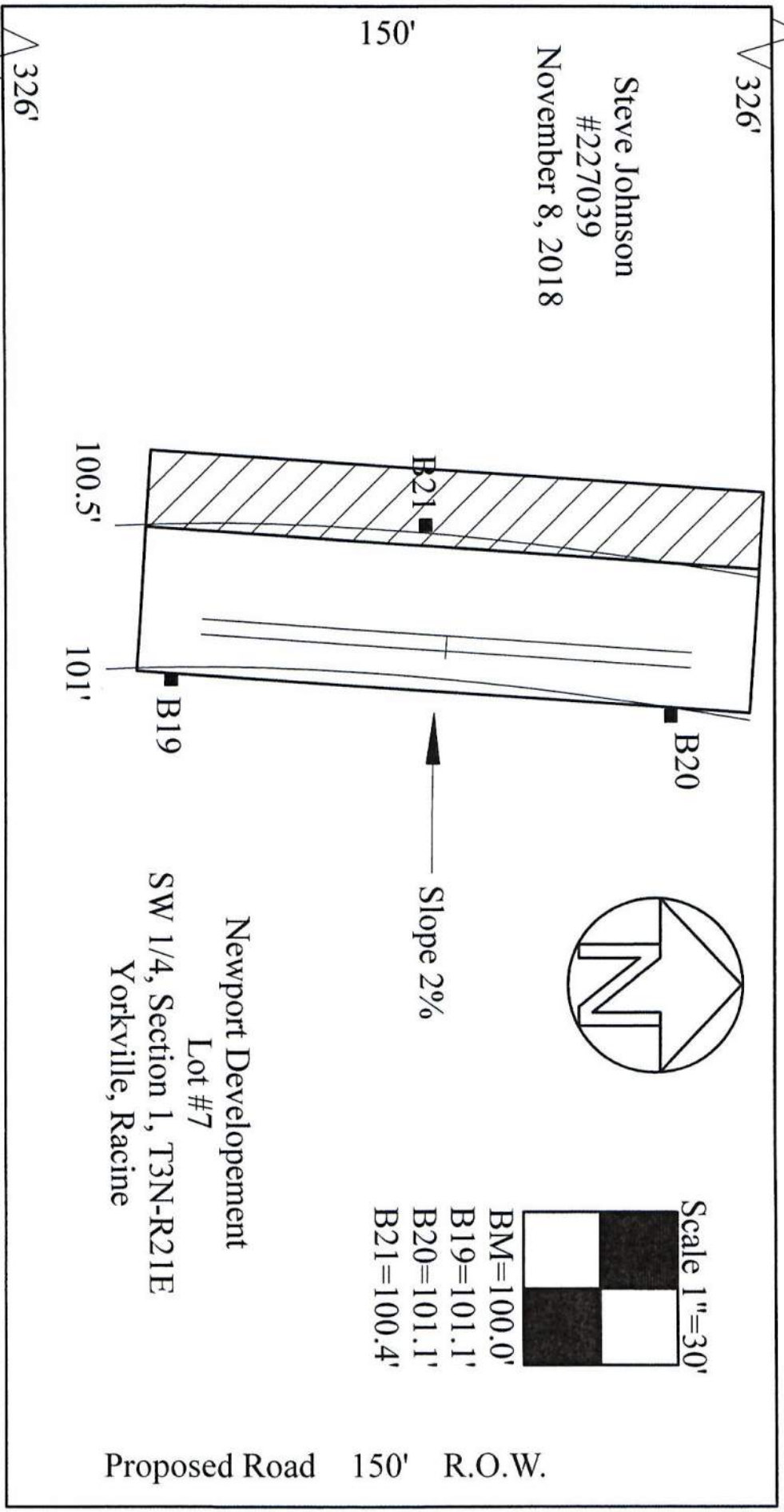

Steve Johnson
#227039
November 8, 2018

Newport Development
Lot #7
SW 1/4, Section 1, T3N-R21E
Yorkville, Racine

Proposed Road 150' R.O.W.

BM is top of bridge guardrail post 371' west along 50Th Rd R.O.W.

Plot Plan



NE corner of lot 11

344.08'

Slope 4%

724'

725'

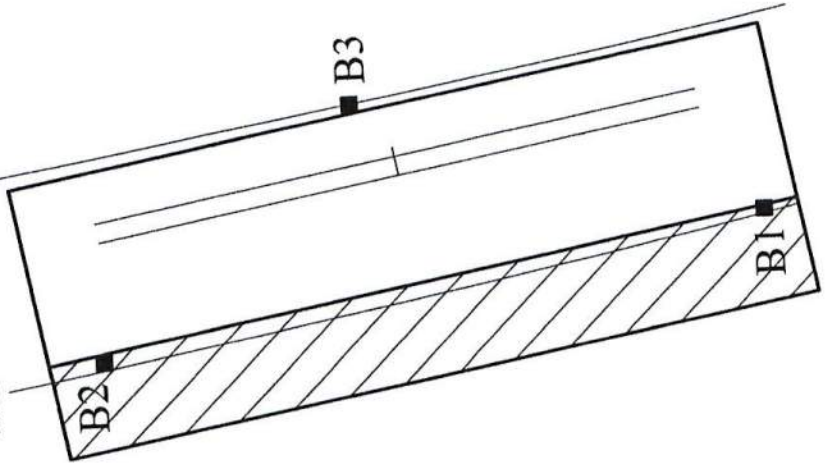

Newport Development
Lot #8
SW 1/4, Section 1, T3N-R21E
Yorkville, Racine

Proposed Road 132.88' R.O.W.

Scale 1"=30'

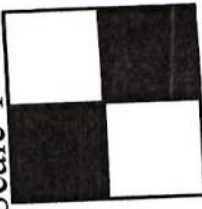

BM=721.23'

B1=724.08'

B2=724.08'

B3=725.08'

326.85'

BM is (sea level) NE corner of lot 11

Plot Plan

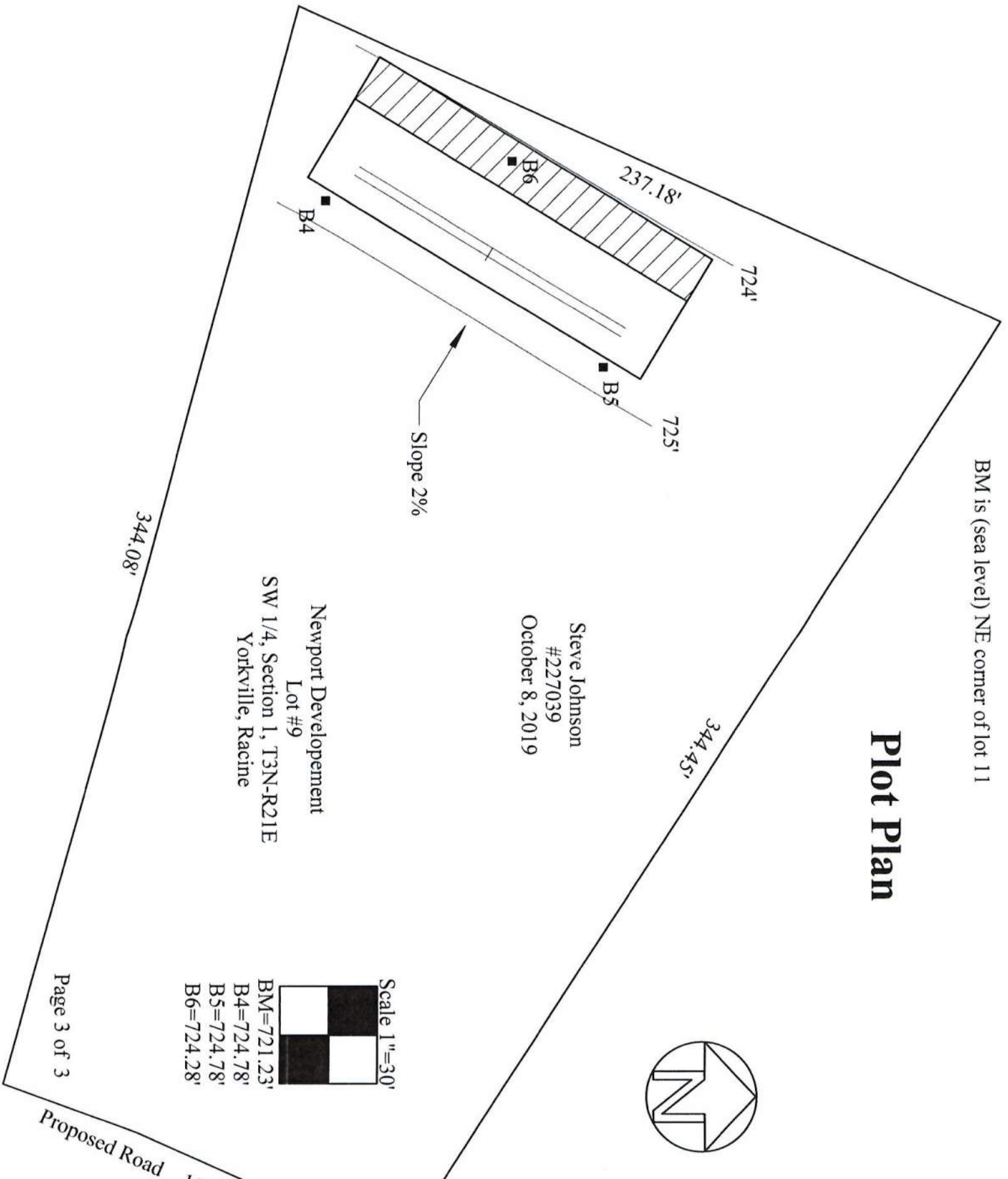

Steve Johnson
#227039
October 8, 2019

Newport Development
Lot #9
SW 1/4, Section 1, T3N-R21E
Yorkville, Racine

Scale 1"=30'
BM=721.23'
B4=724.78'
B5=724.78'
B6=724.28'

Plot Plan

Newport Development
 Lot #10
 SW 1/4, Section 1, T3N-R21E
 Yorkville, Racine

341.59'

BM is (sea level) NE corner of lot 11



726.5'

725.5'

211.45'

Slope 3%

B8

B9

B7

Steve Johnson
 #227039
 October 8, 2019

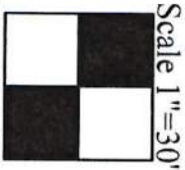

Scale 1"=30'
 BM=721.23'
 B7=726.18'
 B8=726.18'
 B9=725.58'

344.45'

Proposed P...

Plot Plan

★ BM is (sea level) NE corner of lot 11



Slope 2%

722'

242.06'

724'

321.52'

Newport Development
Lot #11
SW 1/4, Section 1, T3N-R21E
Yorkville, Racine

Steve Johnson
#227039
October 8, 2019

Scale 1"=30'



BM=721.23'
B7=723.18'
B8=723.18'
B9=722.48'

341.59'

96.98' arc

Proposed Road R.O.W.

B11

B12

B10



Plot Plan

171.17'

BM is (sea level) NE corner of lot 11

84.21'

259.87'

722.5'

723.5'

722.5'

BM

B15

B13

B14

Slope 2.5%

Newport Development
Lot #12
SW 1/4, Section 1, T3N-R21E
Yorkville, Racine

321.52'

Steve Johnson
#2227039
October 8, 2019

427.08'



Scale 1"=30'

BM=721.23'
B13=723.13'
B14=723.13'
B15=722.48'

Proposed Road R.O.W.
81.54' arc

Plot Plan

* BM is (sea level) NW corner of lot 13



Scale 1"=50'
BM=728.86
B17=730.16
B18=730.16
B19=729.56

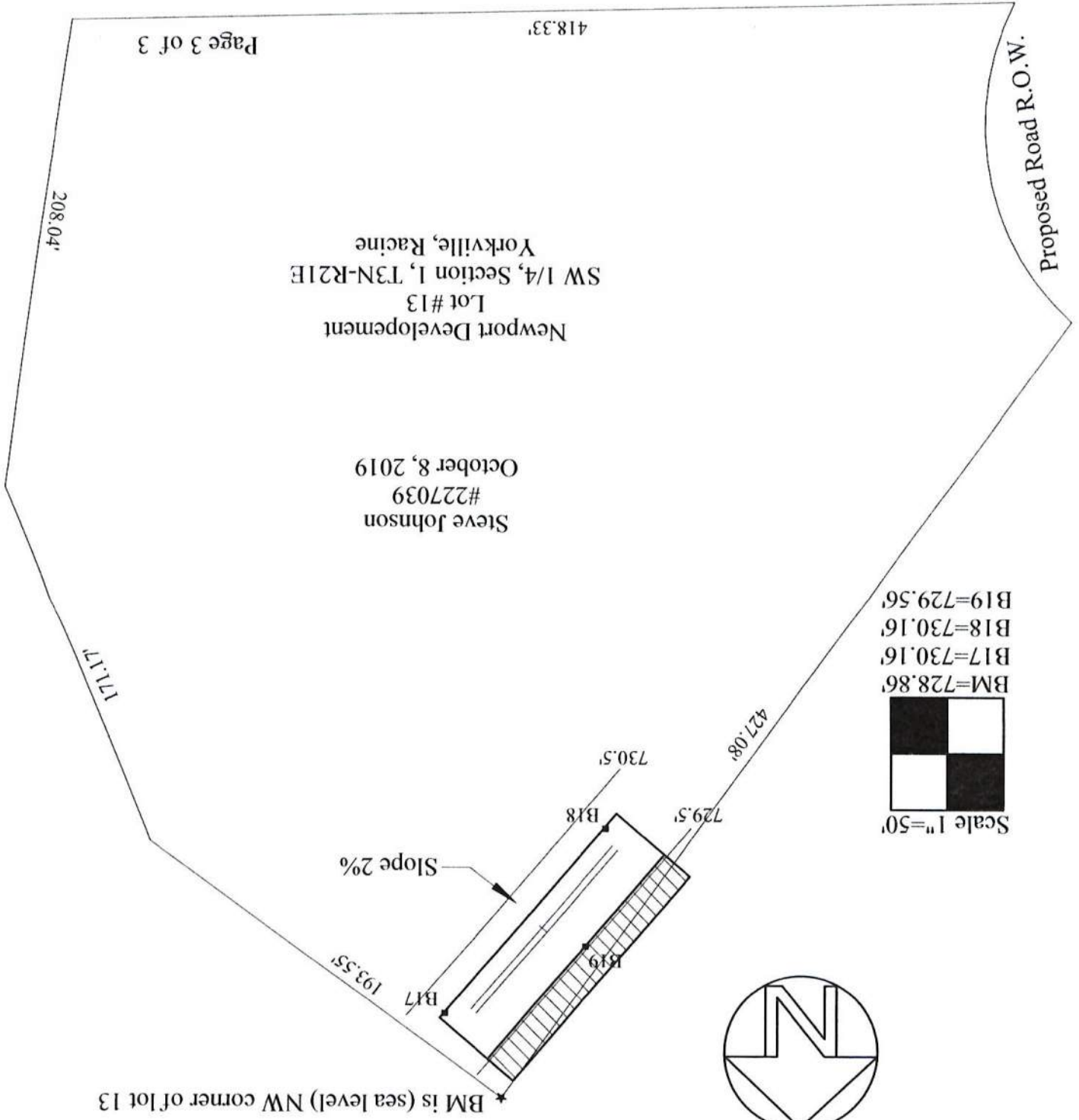

Proposed Road R.O.W.
81.54' arc

Plot Plan

418.33'

BM is top of lot stake in NE corner of 14700 - 50Th Road.

Steve Johnson
#227039
October 8, 2019



109.35'

324.81'

733.5

Slope 1.5%

734.5'

302.47'

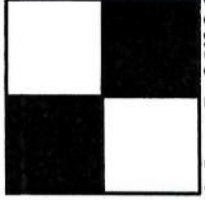

Scale 1"=50'

- BM=731.93'
- B20=734.43'
- B21=734.43'
- B22=733.93'

Newport Development
Lot #14
SW 1/4, Section 1, T3N-R21E
Yorkville, Racine

110.67'

731.93'

734.43' lot corner



Plot Plan



Steve Johnson
 #227039
 October 8, 2019

Scale 1"=40'

 BM=731.93'
 B7=731.43'
 B8=731.43'
 B9=730.43'

